

# ***DACouplings***® ***Dry Aviation Couplings***



## Product Information

## Content

About NPT and BSP threads	22
Advantages	6
Drain Connection	16
Dust plug and cap	17
Enquiry DACouplings	27
Explanation of Designations - 1/2	25
Explanation of Designations - 2/2	26
Filter Strainer - Product information	9-10
Flange Measurement - 1/2	19
Flange Measurement - 2/2	20
Flange Connection	21
Flat seals for thread - 1/2	23
Flat seals for thread- 2/2	24
Hose unit with female thread	7
Hose Unit Option - Long Handle	8
Hose Unit Option - Half long Handle	8
Hose Unit Option - Depot Handle	8
How it works	3
ISO 45 with Ground Connection	10
Military	18
Pressure Drop Curve	3
Pressure Drop Measurement	4
Pressure equalizing valve	5
Pressure relief valve	5
Tank unit with female thread	11
Tank unit with male thread	11
Tank unit with standard flange, 2½" ASA 150 psi	12
Tank unit with standard flange, 3" ASA 150 psi	12
Tank unit with standard flange, DN 65 PN 10/16	13
Tank unit with standard flange, DN 80 PN 10/16i	13
Tank unit with standard flange, TW1 (DIN 28459)	14
Tank unit with standard flange, TW3 (DIN 28459)	14
Tank unit with standard flange, 3" TTMA	15
Tank unit with standard flange, 4" TTMA	15
Tank unit with square flange, 120 mm / 4.72 inch	16
Technical Data	17

# How it works

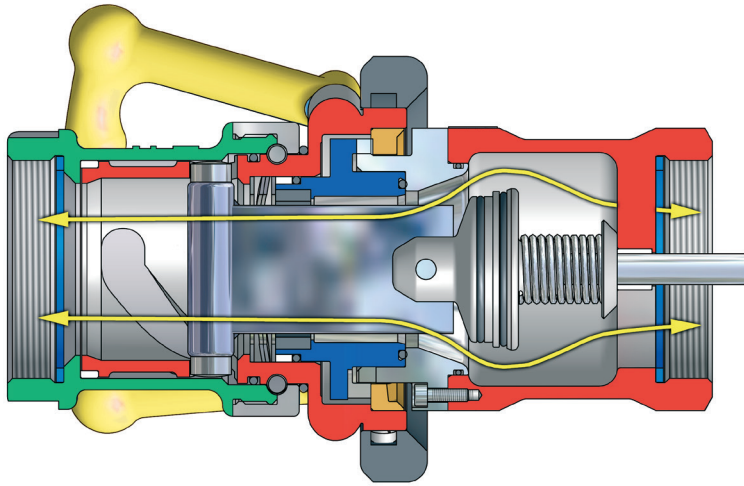

**To connect**  
Push and turn -  
it's coupled - *full flow*

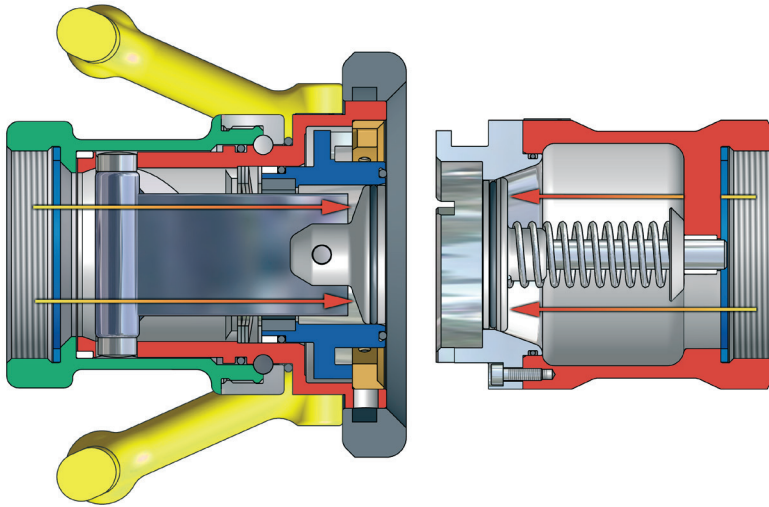

**To disconnect**  
Turn and pull -  
it's released  
- *no spillage*

## Pressure Drop Curve

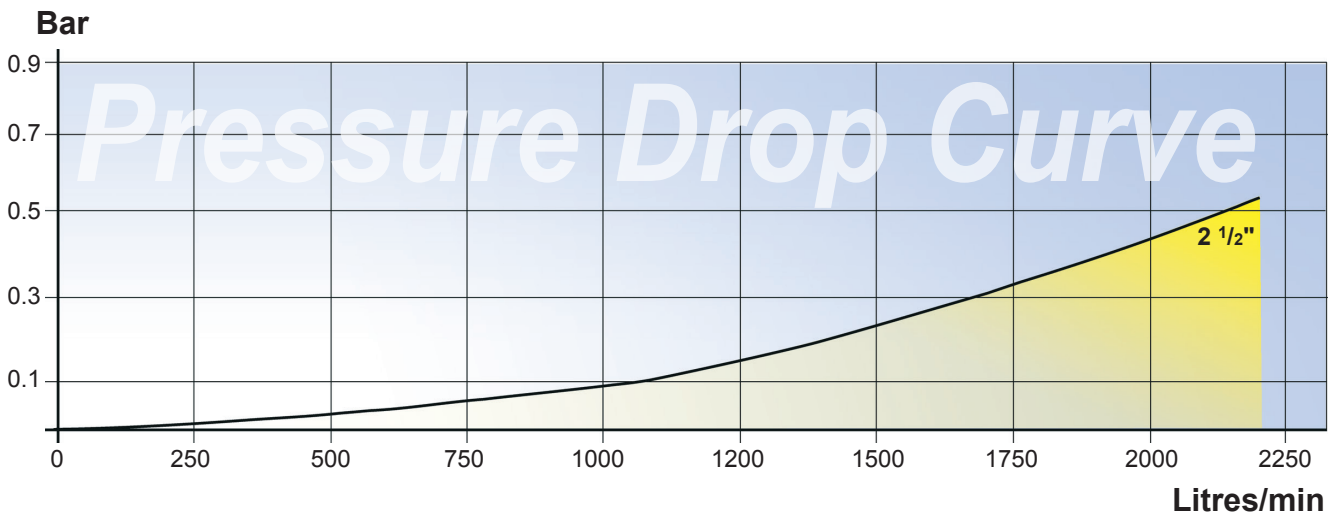

**Test Fluid:** n-Paraffin, **Test Temperature:** 20° C, **Density:** 0,75 kg / dm<sup>3</sup>, **Viscosity:** 1,75 mm<sup>2</sup>/s

No part of this leaflet may be reproduced in any form or by any means without permission in writing from the publisher.

# Pressure Drop Measurement

## Illustration Pressure Drop Measurement According to NATO STANAG 3756, Annex E

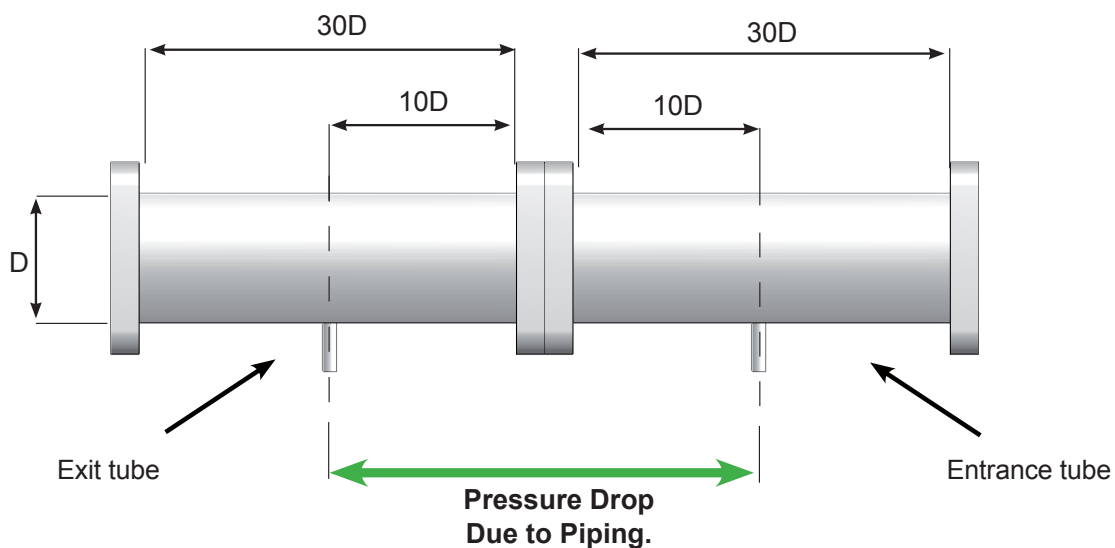
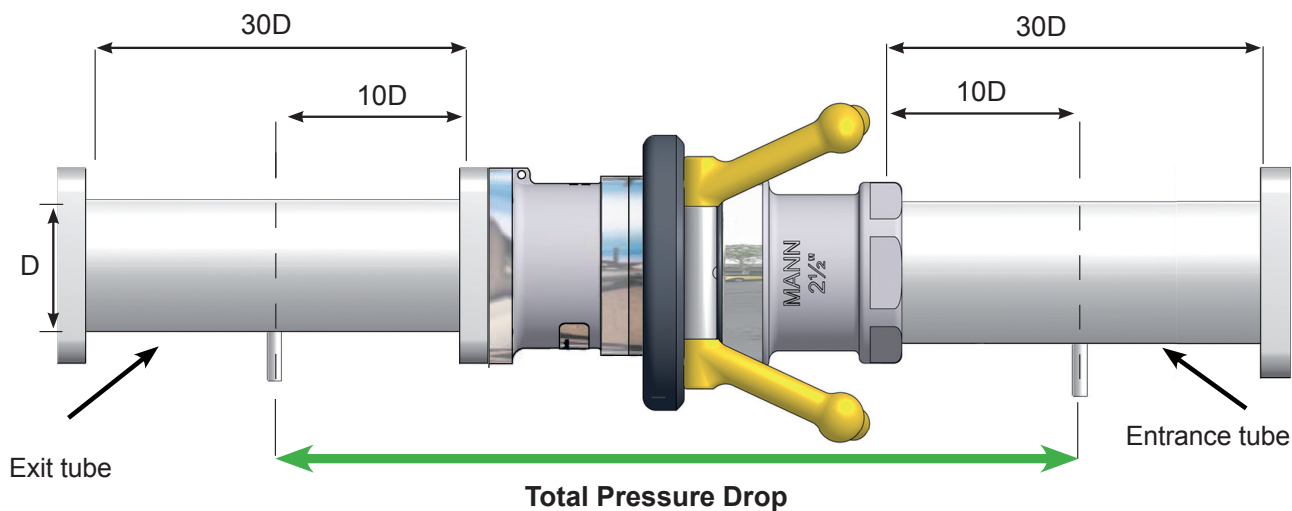

**Pressure Drop DACoupling (ISO45) = Total Pressure Drop - Pressure Drop Due to Piping**

$$\text{Pressure Drop DACoupling} = \Delta P$$

# Pressure equalizing valve Tank unit and Tank unit

## Pressure equalizing valve in ISO 45 Tank unit and STANAG 3756 Tank unit

This system dissipates trapped fluid pressure into hose coupler without spillage, to allow easy connection.

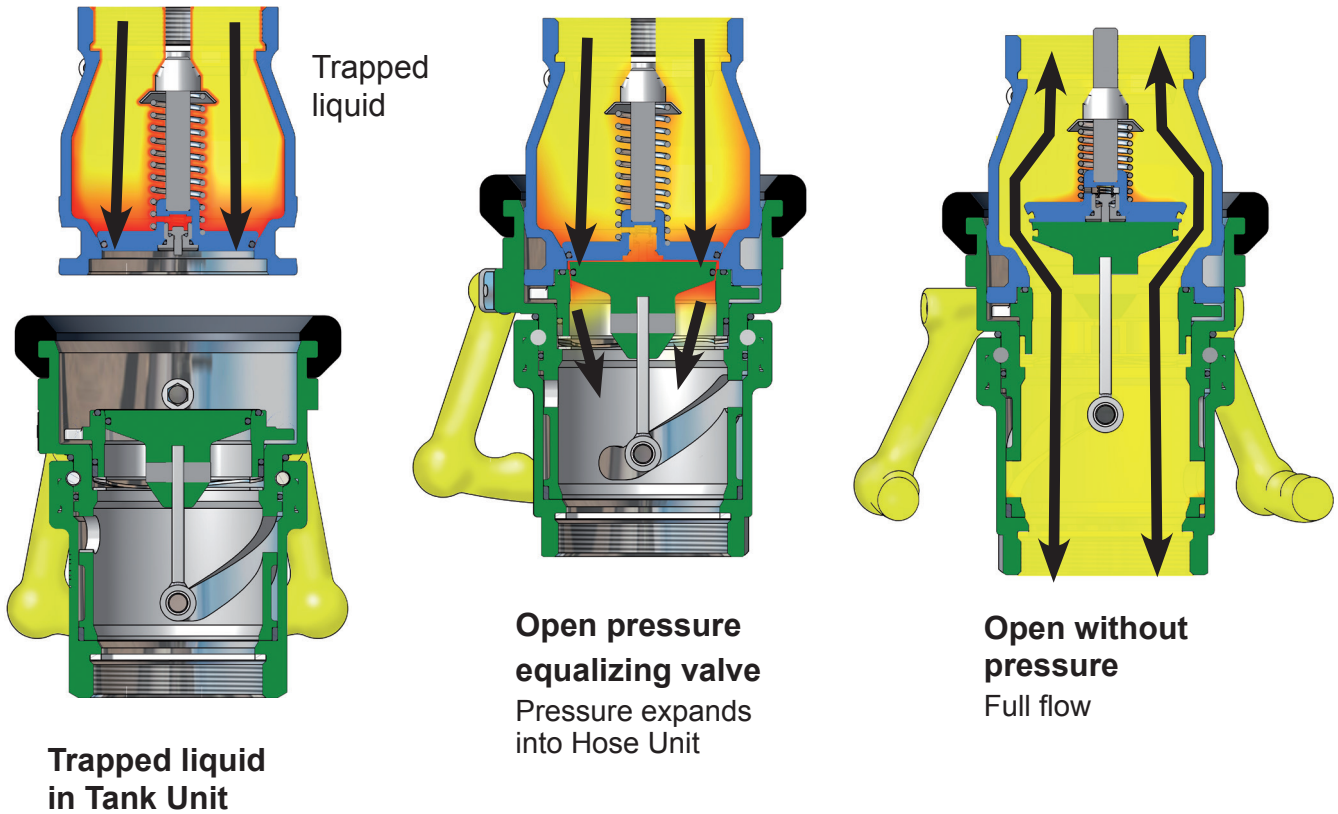

## Pressure relief valve in ISO 45 Tank unit and STANAG 3756 Tank unit

### Pressure Relief Valve (relieve valve, blow off valve)

Under thermal influence the liquid will be warmed up and the pressure increases extremely. To protect the equipment against excessive pressure the PEV opens at a predetermined pressure at an acceptable and riskless limit.

Other applications with the same effect are adapter pieces between different DDCs, hose lines with DACouplings on both sides e.g. for military applications (logistic supply lines).



No part of this leaflet may be reproduced in any form or by any means without permission in writing from the publisher.

# Advantages - All wetted parts in Aluminium and Stainless steel

No yellow parts (Brass and Bronze) in contact with the fuel.

The Tank unit is supplied with parallel BSP threads and flat sealing surface. This allows the use of the full thread length for screwed-on parts. Also available with flange and tapered internal NPT threads.

PTFE (Teflon®) bearing between the piston shaft and the piston guide to eliminate the risk of seizure.

Conical valve seat to eliminate the risk for "piston blow out" when extreme pressure is used.

Coupling ring in brass to minimize the risk of seizure. All parts with media contact are Stainless steel or Aluminium.

PTFE (Teflon®) bearings between the driving plate and the piston guide to eliminate the risk of seizure.

Shaft journal in Stainless Steel embedded in PTFE (Teflon®) to eliminate seizure.

Inner parts in Stainless Steel AISI 316.

Protecting ring in weather resistant rubber. Electrically conductive.

Riveted piston pin to minimize the risk of failure under extreme pressure conditions.

Ball bearings in Stainless Steel.

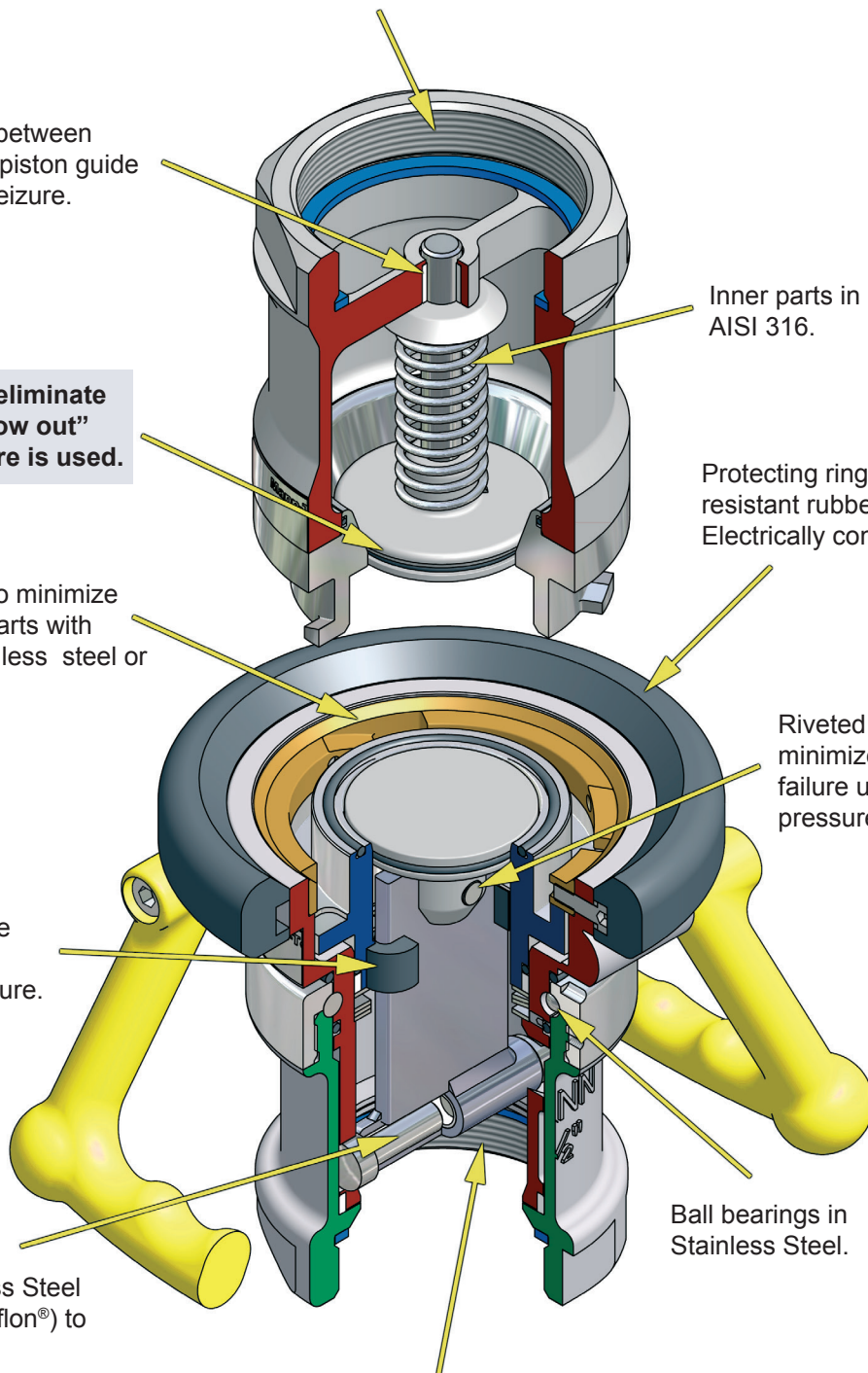

The Hose unit is supplied with parallel BSP threads and flat sealing surface. This allows the use of the full thread length for screwed-on parts. Also available with flange and tapered internal NPT threads.

Teflon® is a registered trademark of DuPont.

No part of this leaflet may be reproduced in any form or by any means without permission in writing from the publisher.

# Hose unit with female thread - Standard Handle

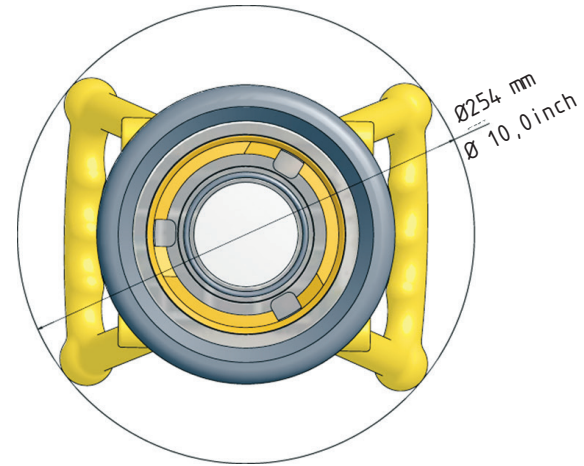
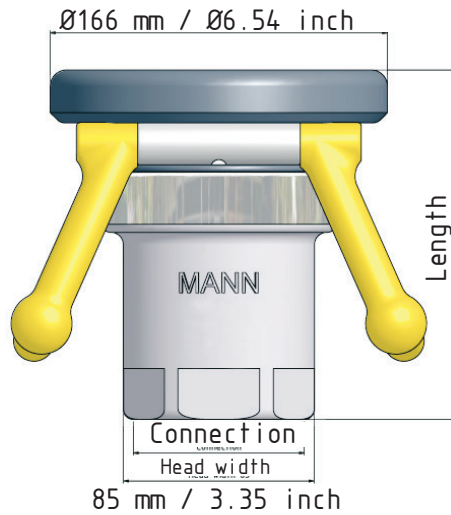
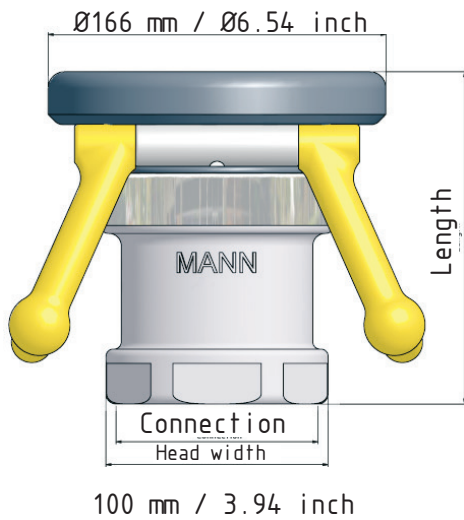

## Threads:

BSP = ISO 228

NPT = B1.20.1

Connection	Length	Head width	Weight	Code No
2½" BSP	64 mm/6.46 inch	85 mm / 3.35 inch	3.4 kg / 7.5 lbs	<b>F312B1101B</b>
3" BSP	164 mm/6.46 inch	100 mm / 3.94 inch	3.5 kg / 7.7 lbs	<b>F314B1101B</b>
2½" NPT	172 mm/6.77 inch	85 mm / 3.35 inch	3.4 kg / 7.5 lbs	<b>F313B1101</b>
3" NPT	174 mm/6.85 inch	100 mm / 3.94 inch	3.5 kg / 7.7 lbs	<b>F315B1101</b>

## Hose Unit, flanged inlet

Flange1)	Material	Seal O-ring	Code No
undrilled Ø210 mm	<b>Al</b>	Standard <b>FPM/KFM</b> (Viton®)	<b>F320B1101</b>
DN 65 PN 10/16 Type A			<b>F333B1101</b>
DN 80 PN 10/16 Type A			<b>F336B1101</b>
2½" ASA 150 psi			<b>F359B1101</b>
3" ASA 150 psi			<b>F361B1101</b>
TW1 (DN80)			<b>F365B1101</b>
TW3 (DN100)			<b>F366B1101</b>
3" TTMA			<b>F367B1101</b>
4" TTMA			<b>F368B1101</b>

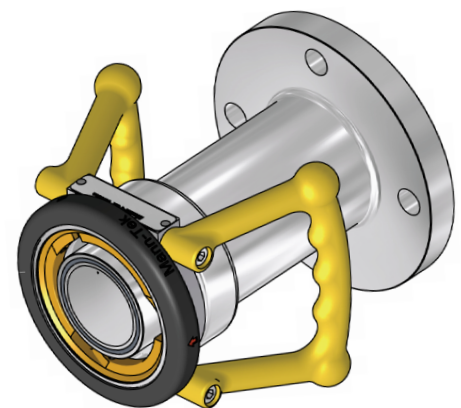

### We make specials

Other materials, connection and sealings on request.

1) Flanges according to EN 1092 , ANSI B16.5 and DIN 28459.

Viton® (FPM) and Teflon® (FPM/KPM) are registered trademarks of DuPont, DuPont Elastomers. Vulkollan® is registered trademark of Bayer AG

ООО «ТИ-СИСТЕМС» ИНЖИНИРИНГ И ПОСТАВКА ТЕХНОЛОГИЧЕСКОГО ОБОРУДОВАНИЯ

Интернет: [www.tisys.ru](http://www.tisys.ru) [www.tisys.kz](http://www.tisys.kz) [www.tisys.by](http://www.tisys.by) [www.tesec.ru](http://www.tesec.ru) [www.ти-системс.рф](http://www.ти-системс.рф)

Телефоны: +7 (495) 7774788, 7489626, (925) 5007155, 54, 65

Эл. почта: [info@tisys.ru](mailto:info@tisys.ru) [info@tisys.kz](mailto:info@tisys.kz) [info@tisys.by](mailto:info@tisys.by)

## Hose Unit Option - Long Handle

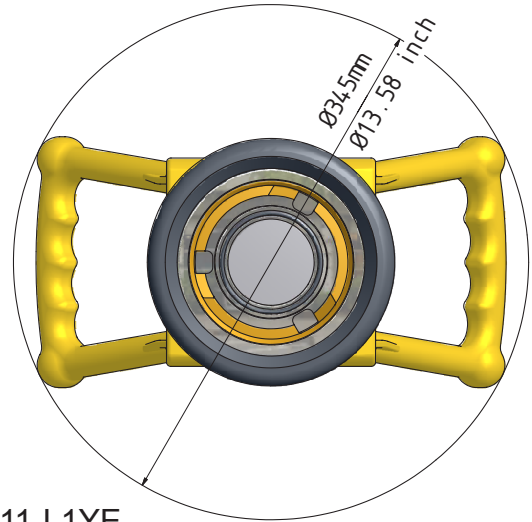
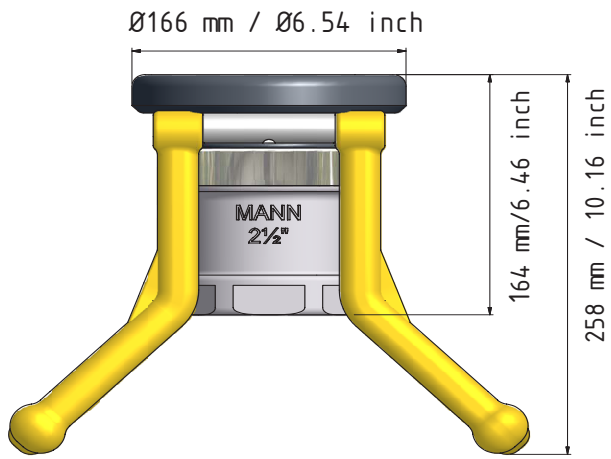

**How to Order** Code nr: Code nr. Hose Unit + H-F3-11-L1YE

## Hose Unit Option - Half long Handle

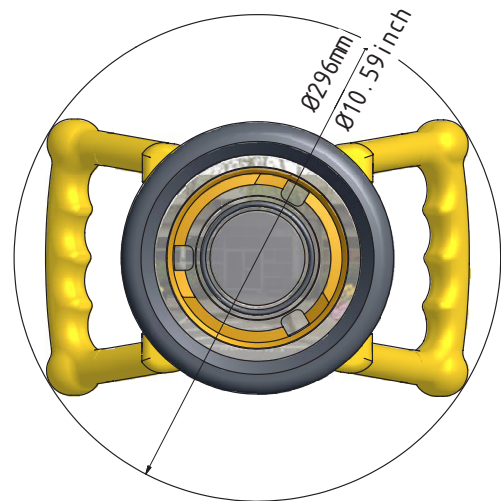
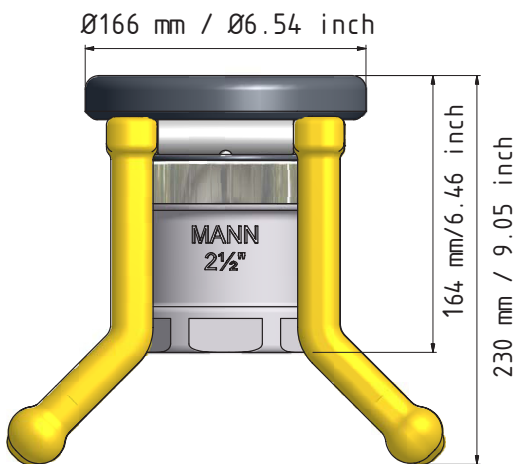

**How to Order** Code nr: Code nr. Hose Unit + H-F3-11-L2YE

## Hose Unit Option - Depot Handle

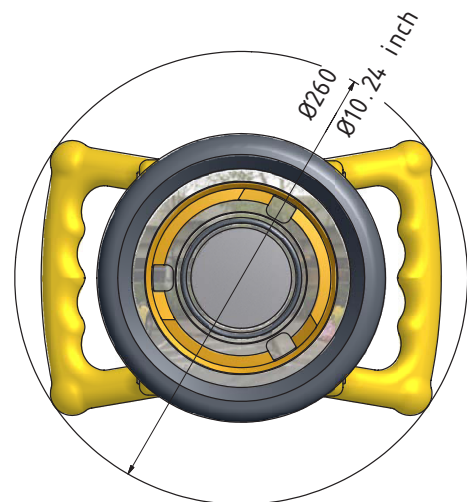
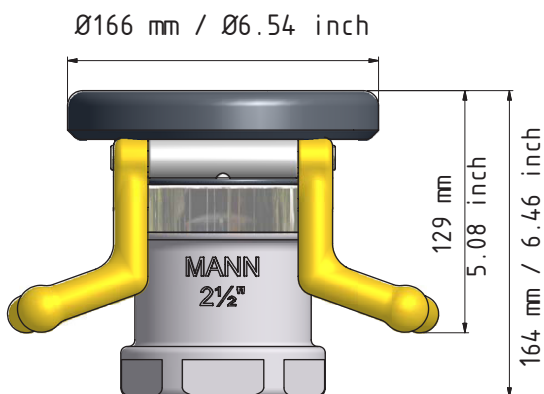

**How to Order** Code nr: Code nr. Hose Unit + H-F3-11-L3YE



# Filter Strainer - Product information

The Filter Strainer is designed to adapt on the DACoupling according to the ISO45 standard. The integrated view glass makes it easy to check when the filter has to be cleaned. Easy servicing is guaranteed by a new bayonet connection.

The Filter Strainers are available with 2½" BSP/NPT and 3" BSP/NPT connections.

Sight flow indicator with male BSP thread screws into a ISO 45 Hose Unit / Coupler with female threads.

There are 3 different filter types, 45 mesh, 60 mesh and 100 mesh. When order replace XX with -45 for 45 mesh, -60 for 60 mesh and -10 for 100 mesh.

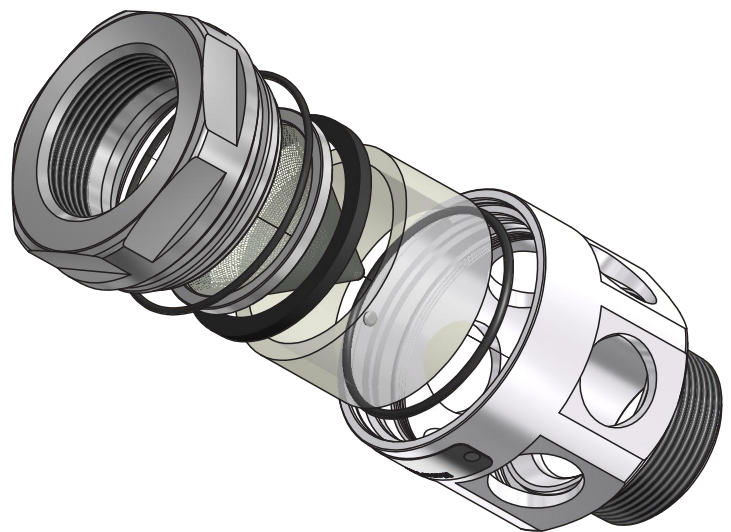
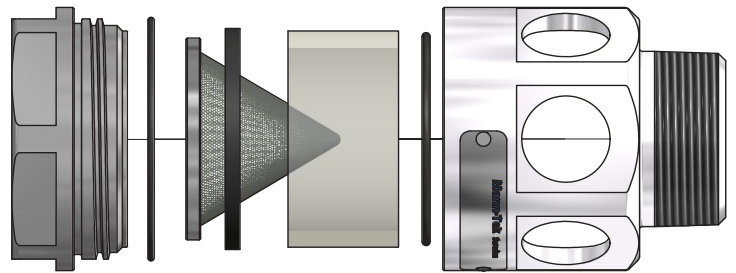
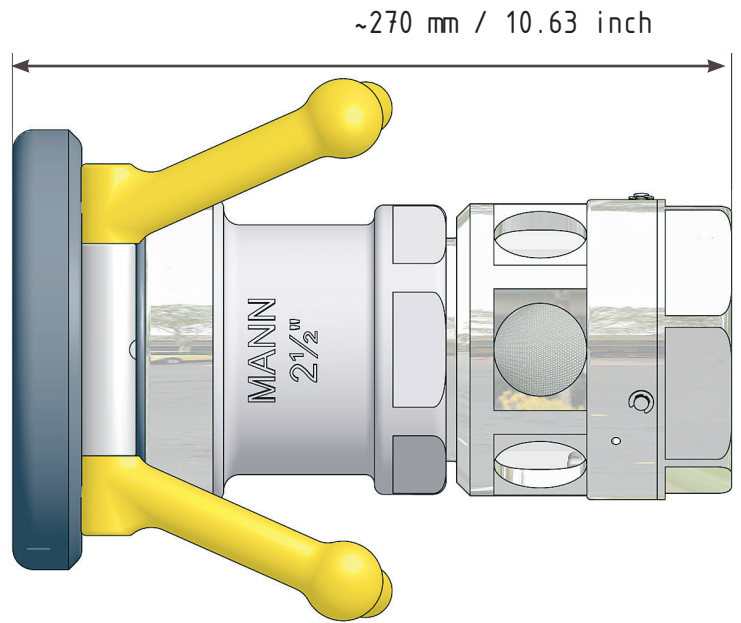

No part of this leaflet may be reproduced in any form or by any means without permission in writing from the publisher.

# Filter Strainer - Product information



45 mesh

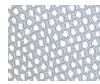

60 mesh

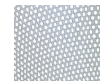

100 mesh

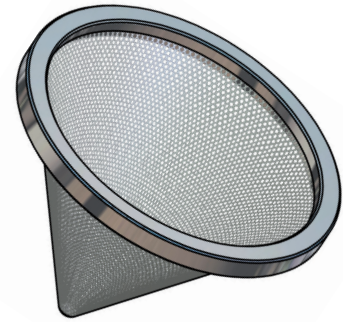
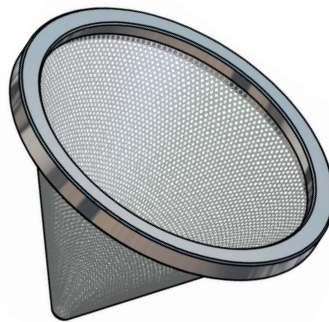
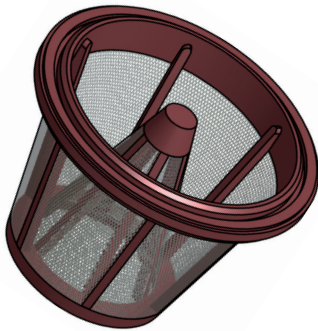

## Standard connections:

Other combinations or connections on request.

Size	End connection (female)	HU connection (male)
U1280S1101-XX	2½" BSP	2½" BSP
U1281S1101-XX	2½" BSP	2½" NPT
U1380S1101-XX	2½" NPT	2½" BSP
U1381S1101-XX	2½" NPT	2½" NPT
U1482S1101-XX	3" BSP	3" BSP
U1483S1101-XX	3" BSP	3" NPT
U1582S1101-XX	3" NPT	3" BSP
U1583S1101-XX	3" NPT	3" NPT

## ISO 45 with Ground Connection

Electrostatic charges can be generated by a variety of circumstances. Ignition of flammable vapours is possible by discharge of static.

Electrical conductive hoses and anti-static additives reduces the risk but might not be sufficient. Than the aircraft, the fuelling vehicle, and all accessories including hose nozzle, filters and other equipment through which the fuel passes must all be electrically bonded.

Such connections must always be attached to appropriate bonding connections thus providing a conductive path to equalize potential.

Removal of the bonding connection must always be the last operation.



Ground cable assembly with solid brass clamp and bold. Cable with plastic coating.

No part of this leaflet may be reproduced in any form or by any means without permission in writing from the publisher.

# Tank unit with female thread

Body material in aluminium and stainless steel.

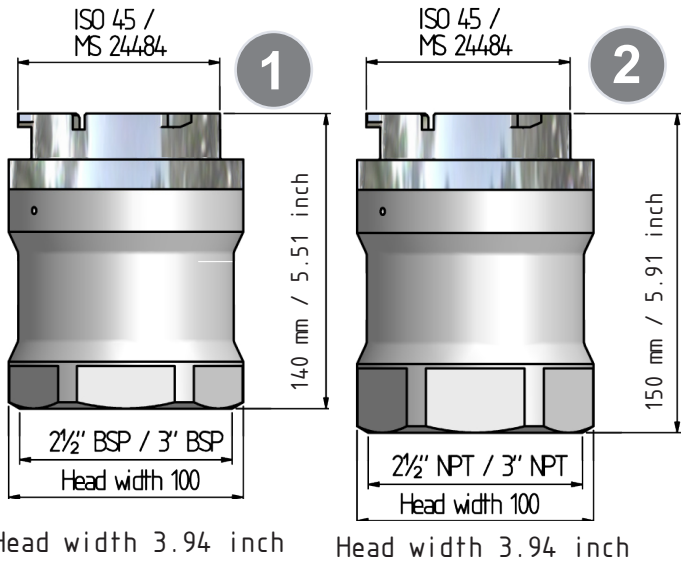

Connection	Material	Weight	Code No
1 2 1/2" BSP	AL	2.3 kg / 5.1 lbs	G312A1401B
1 3" BSP		2.3 kg / 5.1 lbs	G314A1401B
2 2 1/2" NPT		2.3 kg / 5.1 lbs	G313A1401B
2 3" NPT		2.3 kg / 5.1 lbs	G315A1401B
2 1/2" BSP	SS	-	G312A4401B
3" BSP		-	G314A4401B
2 1/2" NPT		-	G313A4401B
3" NPT		-	G315A4401B

Working pressure:	Test pressure:
10 bar / 150 psi	15 bar / 225 psi

Threads:
BSP = ISO 228, NPT = B1.20.1

# Tank unit with male thread

Body material in aluminium and stainless steel.

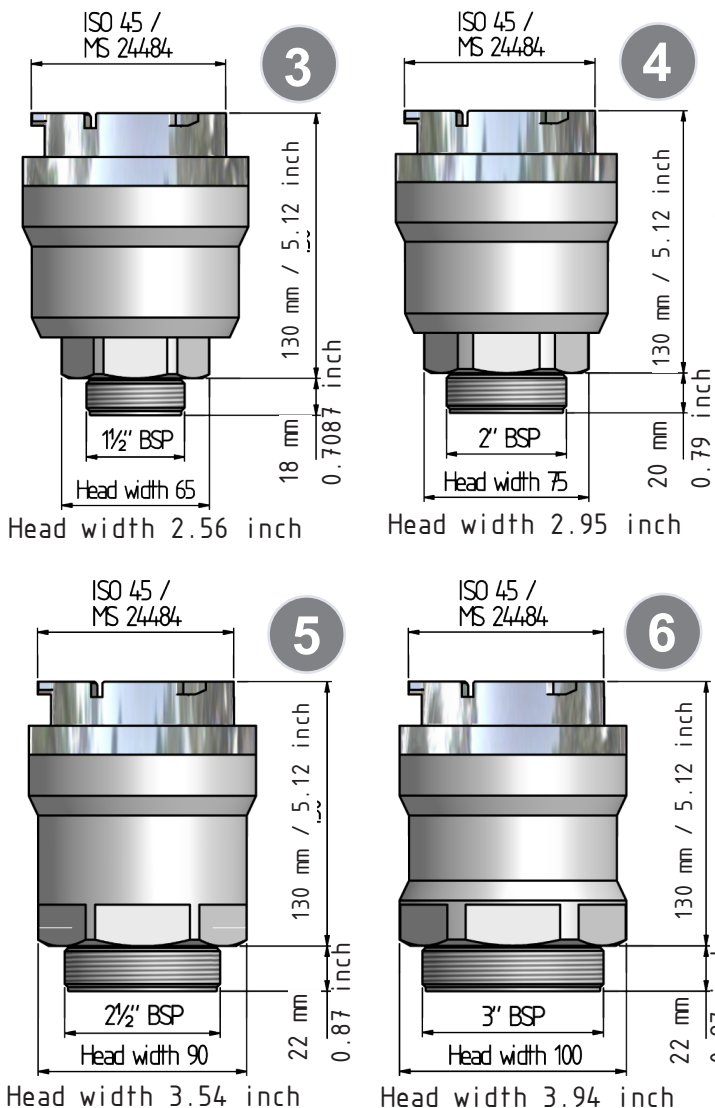

Connection	Material	Weight	Code No
1 1 1/2" BSP	AL	2.1 kg / 4.6 lbs	G375A1401B
1 2" BSP		2.2 kg / 4.8 lbs	G378A1401B
2 2 1/2" BSP		2.2 kg / 4.8 lbs	G380A1401B
2 3" BSP		2.3 kg / 5.1 lbs	G382A1401B
1 1/2" BSP	SS	-	G375A4401B
2" BSP		-	G378A4401B
2 1/2" BSP		-	G380A4401B
3" BSP		-	G382A4401B

Working pressure:	Test pressure:
10 bar / 150 psi	15 bar / 225 psi

Threads:
BSP = ISO 228, NPT = B1.20.1

No part of this leaflet may be reproduced in any form or by any means without permission in writing from the publisher.

# Tank unit (Ground unit) with standard flange, 2½" ASA 150 psi

Body material in aluminium and stainless steel.

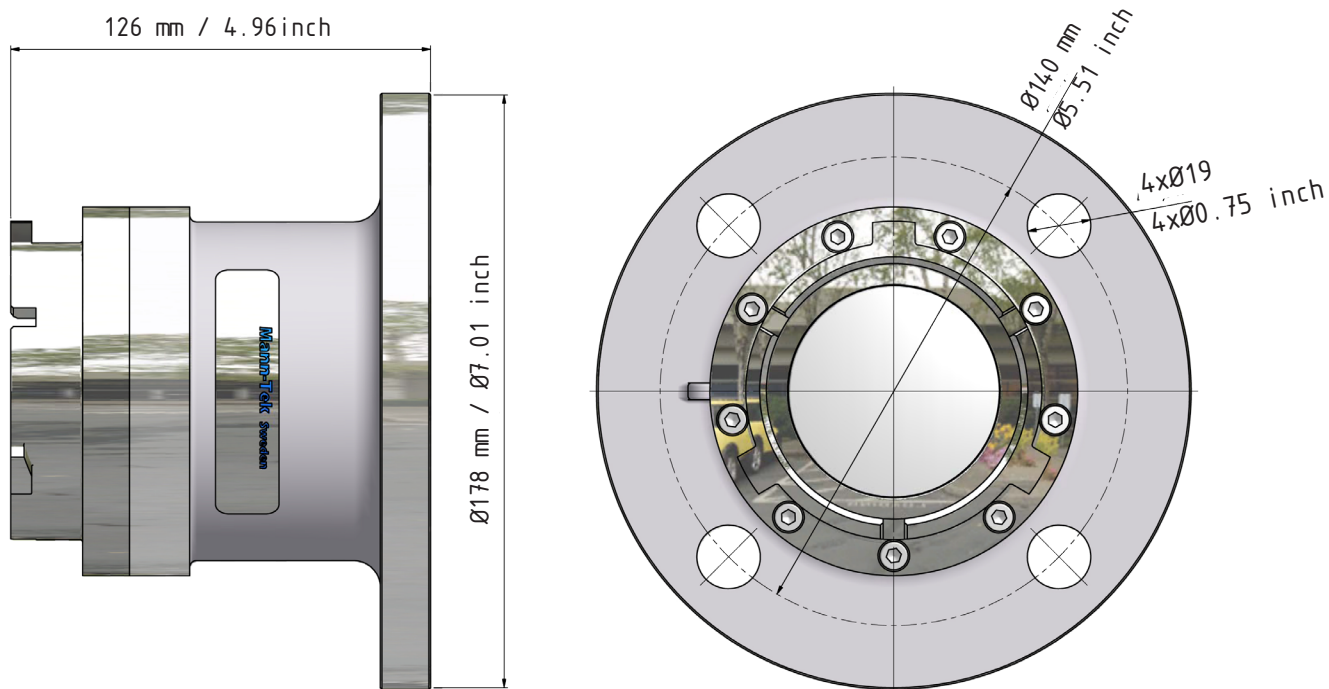

Flange	Material (Body)	Weight	Code No
2½" ASA 150 psi	AL	2.7 kg / 6.0 lbs	G359D1401
2½" ASA 150 psi	SS	-	G359B4401

# Tank unit (Ground unit) with standard flange, 3" ASA 150 psi

Body material in aluminium and stainless steel.

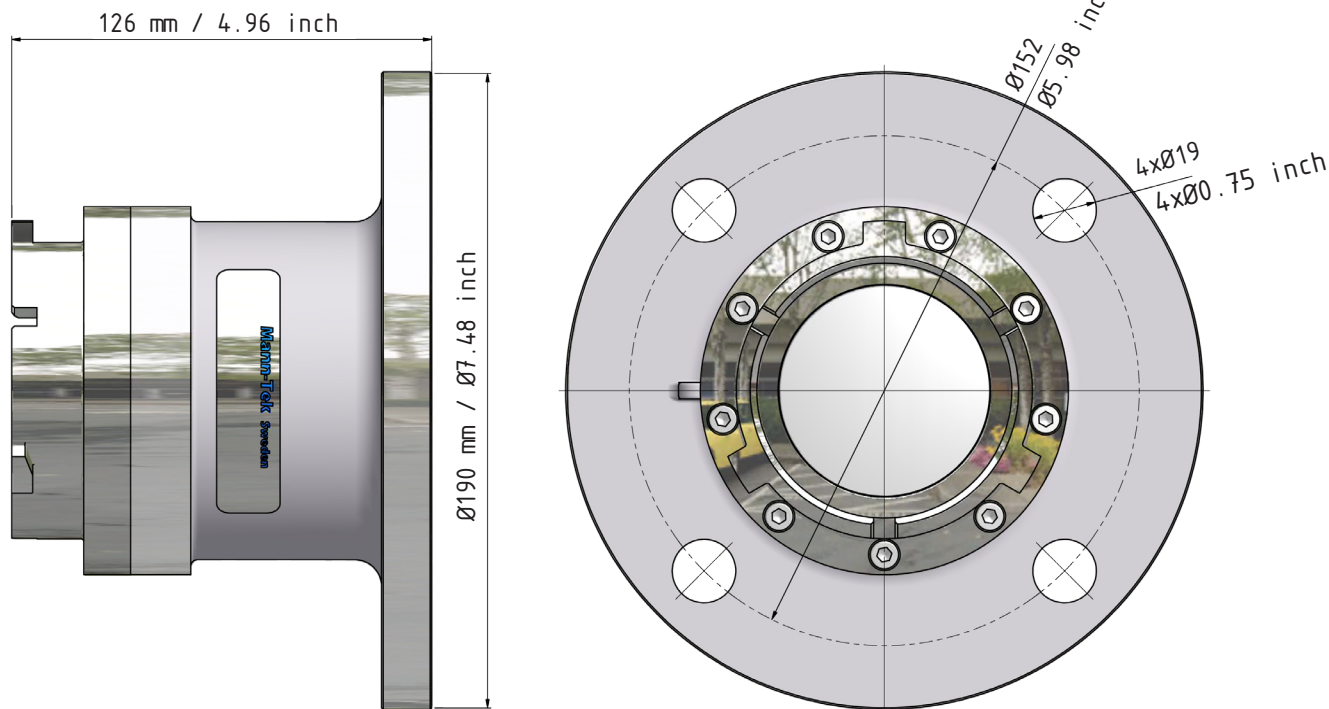

Flange	Material (Body)	Weight	Code No
3" ASA 150 psi	AL	2.9 kg / 6.4 lbs	G361D1401
3" ASA 150 psi	SS	-	G361B4401

# Tank unit (Ground unit) with standard flange, DIN DN 65 PN 10/16

Body material in aluminium and stainless steel.

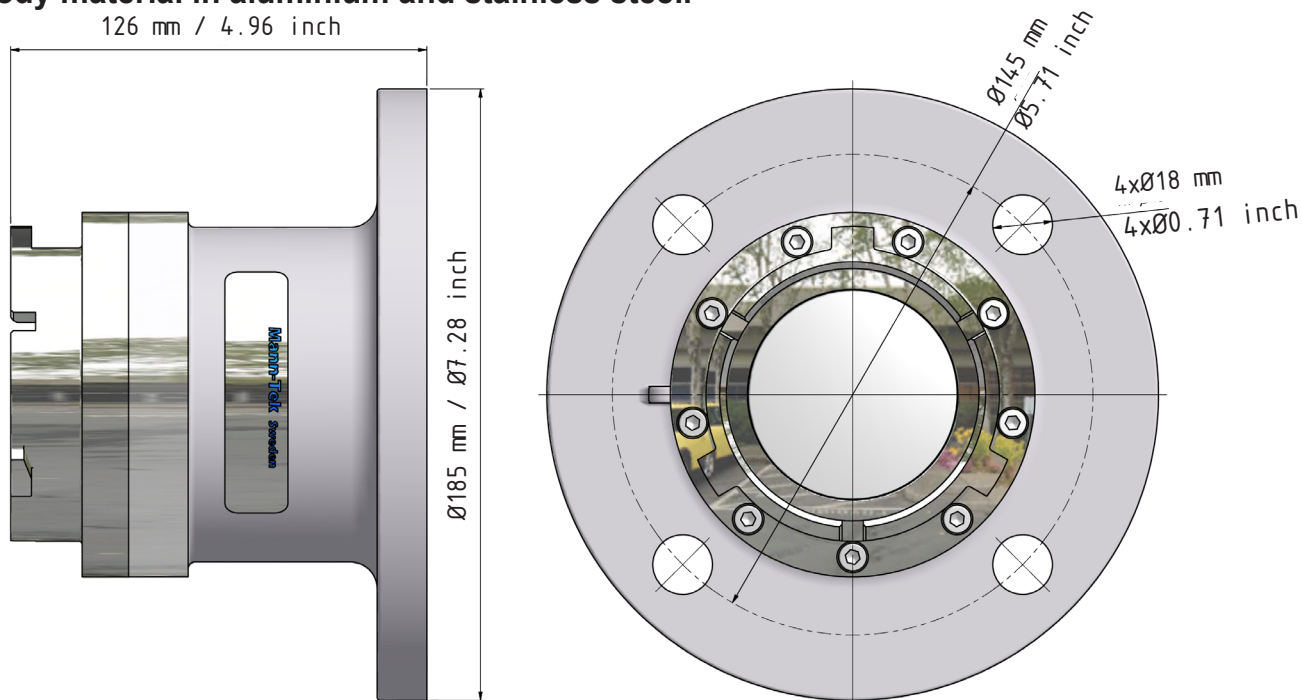

Flange	Material (Body)	Weight	Code No
DN 65 PN 10/16	AL	2.8 kg 6.2 lbs	G333D1401
DN 65 PN 10/16	SS	-	G333B4401

# Tank unit (Ground unit) with standard flange, DIN DN 80 PN 10/16

Body material in aluminium and stainless steel.

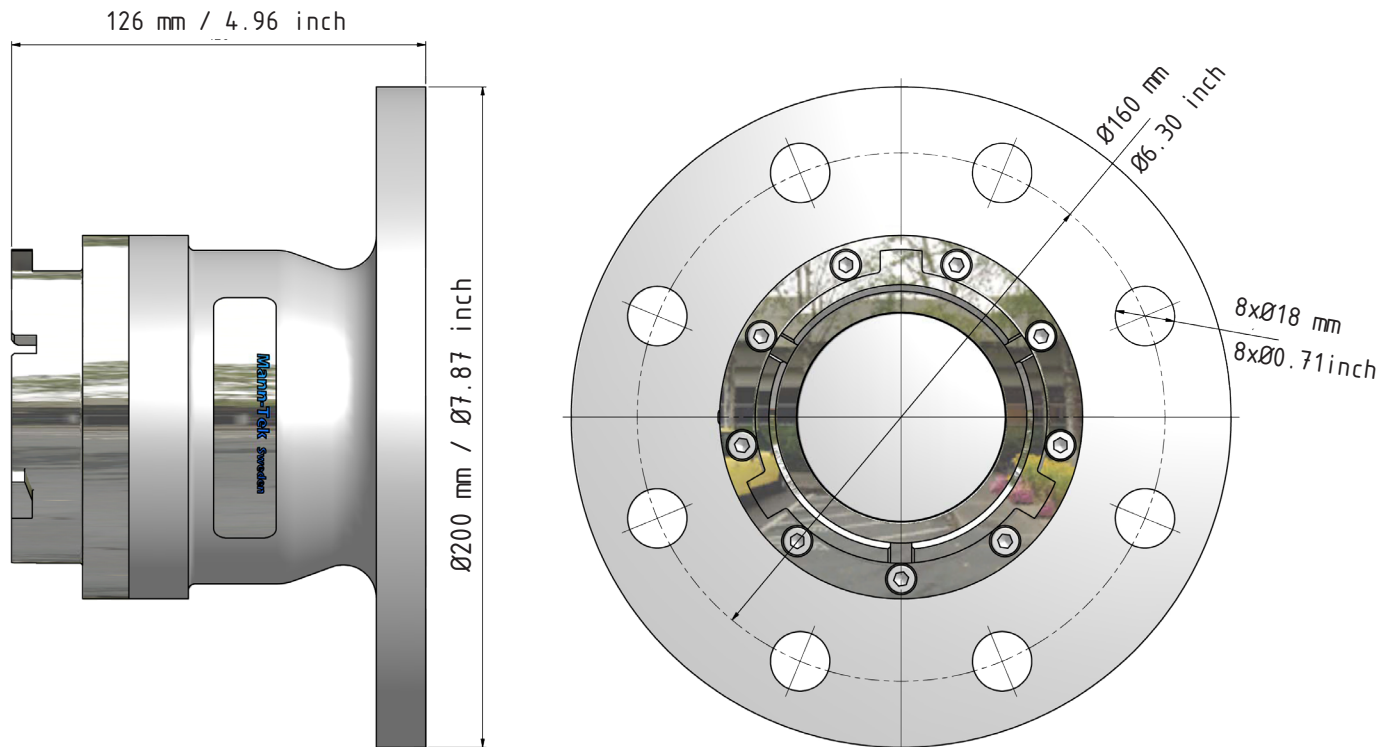

Flange	Material (Body)	Weight	Code No
DN 80 PN 10/16	AL	3.0 kg / 6.6 lbs	G336D1401
DN 80 PN 10/16	SS	-	G336B4401

# Tank unit (Ground unit) with standard flange, TW1 (DIN 28459)

Body material in aluminium and stainless steel.

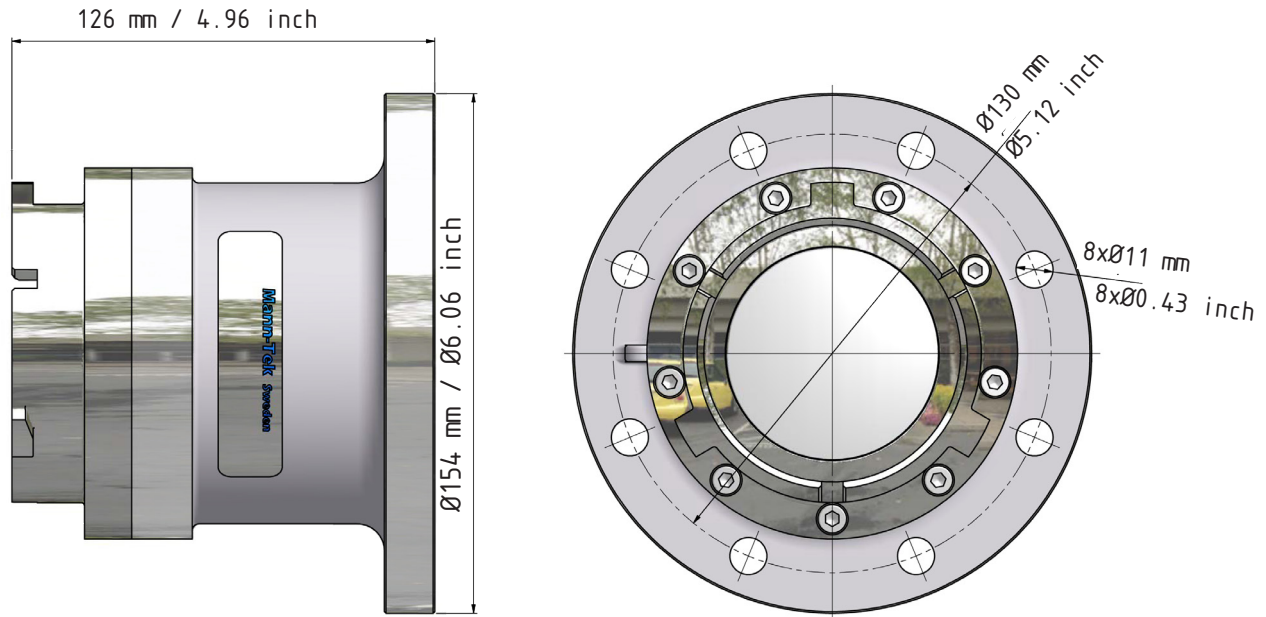

Flange	Material (Body)	Weight	Code No
TW1 (DIN 28459)	AL	2.5 kg / 5.5 lbs	G365D1401
TW1 (DIN 28459)	SS	-	G365B4401

# Tank unit (Ground unit) with standard flange, TW3 (DIN 28459)

Body material in aluminium and stainless steel.

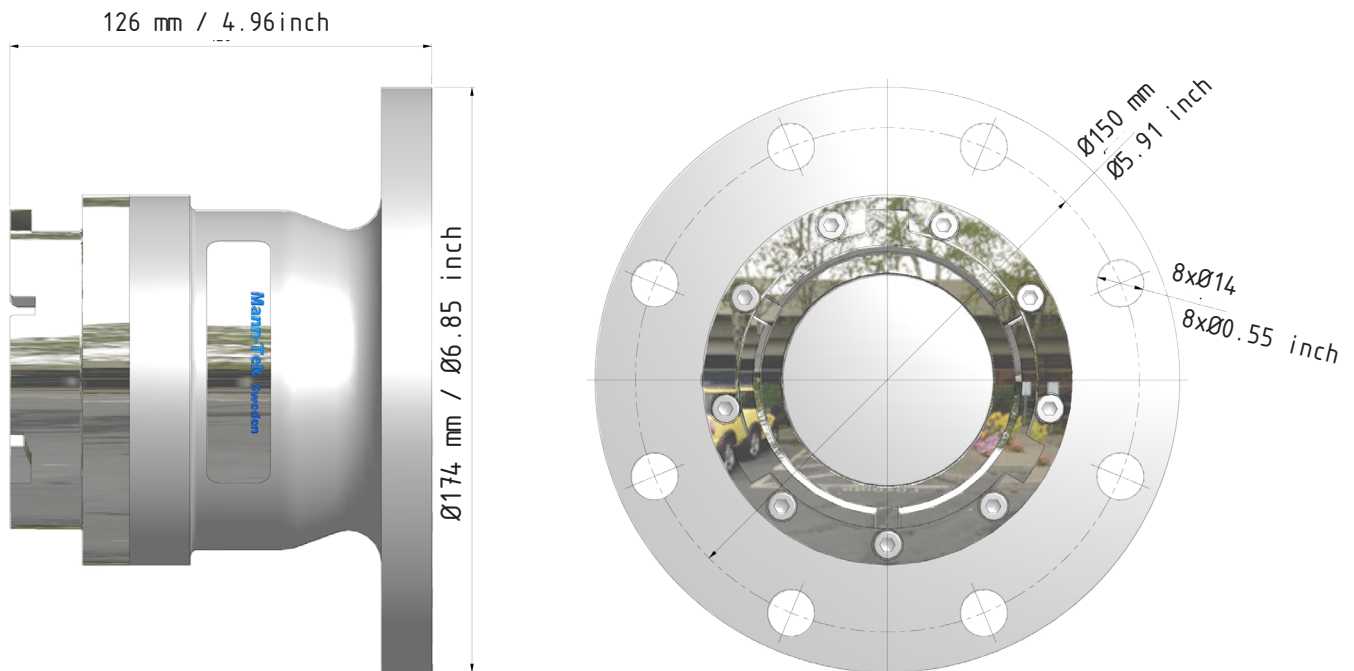

Flange	Material (Body)	Weight	Code No
TW3 (DIN 28459)	AL	2.9 kg / 6.4 lbs	G366D1401
TW3 (DIN 28459)	SS	-	G366B4401

# Tank unit (Ground unit) with standard flange, 3" TTMA

Body material in aluminium and stainless steel.

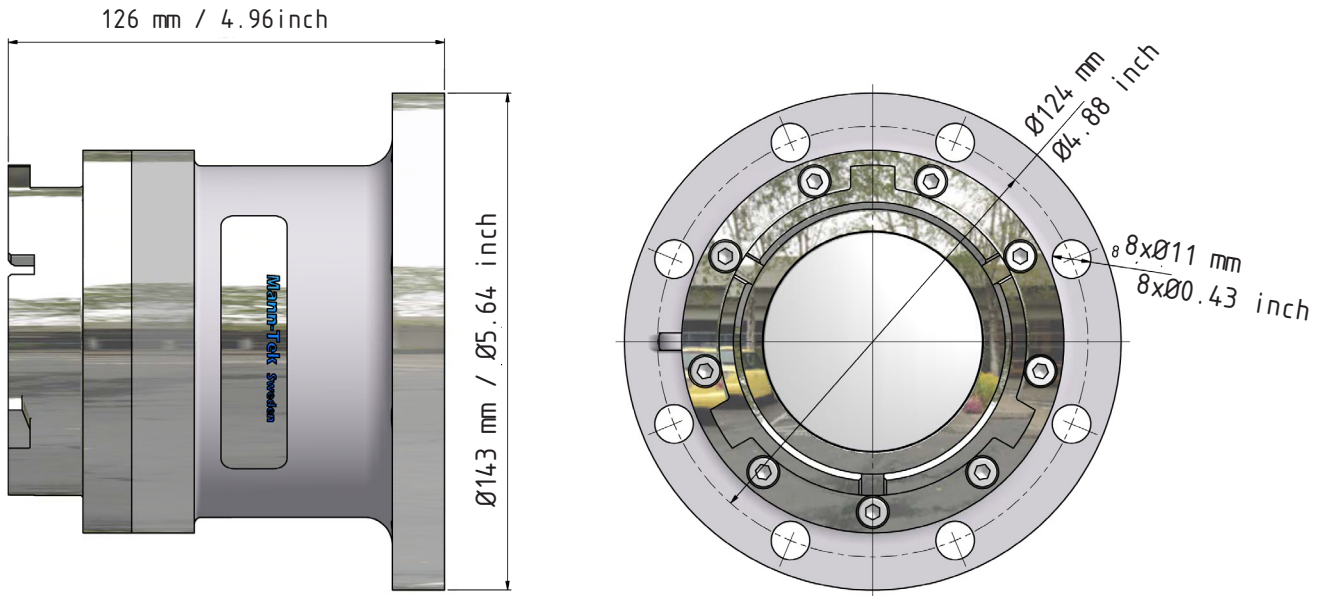

Flange	Material (Body)	Weight	Code No
3" TTMA	AL	2.4 kg / 5.3 lbs	G367D1401
3" TTMA	SS	-	G367B4401

# Tank unit (Ground unit) with standard flange, 4" TTMA

Body material in aluminium and stainless steel.

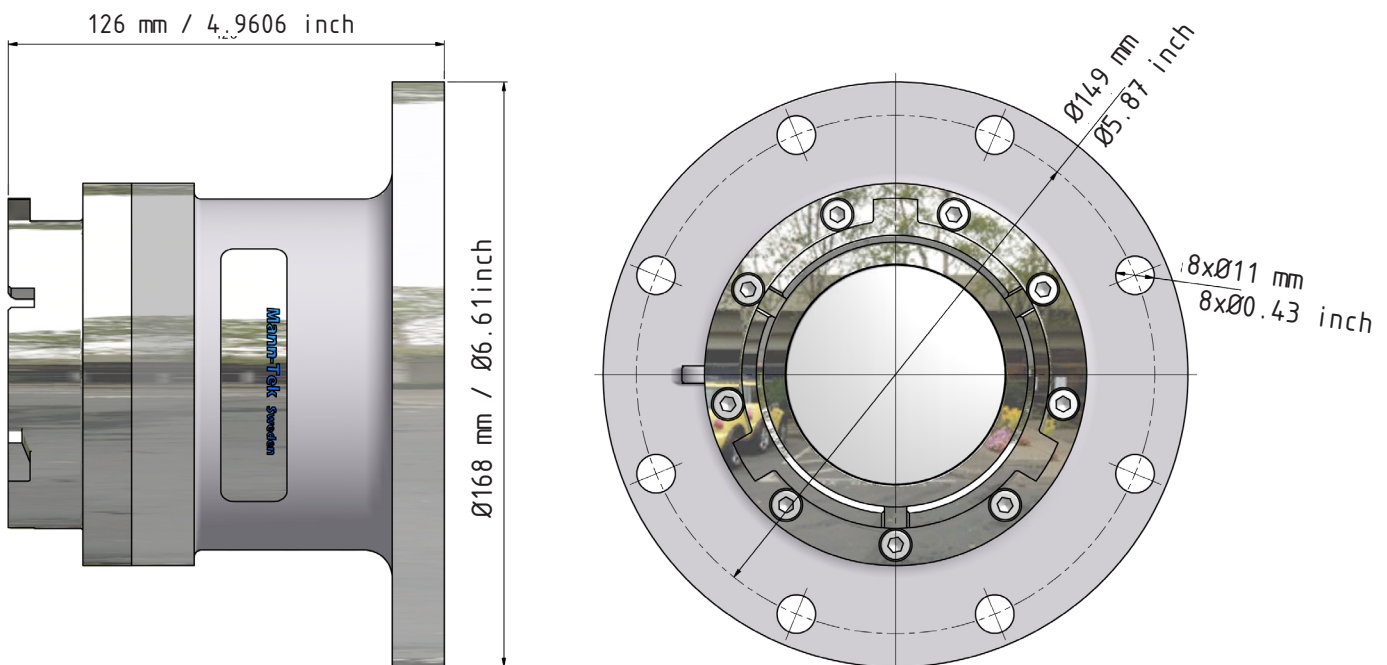

Flange	Material (Body)	Weight	Code No
4" TTMA	AL	2.6 kg / 5.7 lbs	G368D1401
4" TTMA	SS	-	G368B4401

No part of this leaflet may be reproduced in any form or by any means without permission in writing from the publisher.

# Tank unit (Ground unit) with square flange 120 mm

Body material in aluminium and stainless steel.

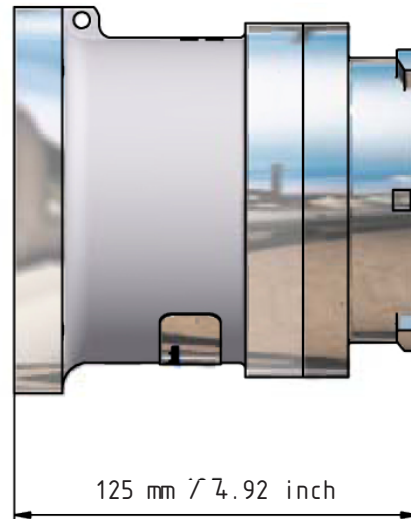
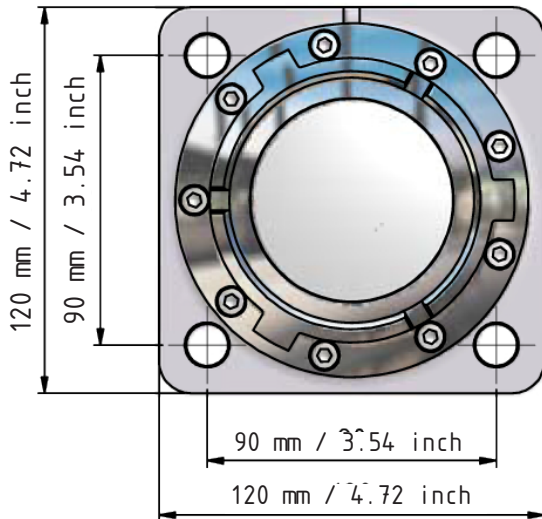

Flange	Material (Body)	Weight	Code No
Square flange, 120 mm / 4.72 inch	AL	2.7 kg / 6.0 lbs	G3107D1401
Square flange, 120 mm / 4.72 inch	SS	-	G3107B4401

## Drain Connection

### Option Drain connection

Use Mann-Tek ISO45 with Drain connection for easy draining and sampling of your system.

Available in all Tank units with flange

**Drain connection:** 3/8" ( thread standard)

Other threads on request.



**How to Order:** Code nr. + D-G3-11-C1



# Dust plug and cap



**Dust Cap (for Tank Unit)**

Code nr:	Material:	Weight:
K300A1101	Aluminium	0,5 kg / 1.10 lbs
K300A2201	Composite <sup>1)</sup>	0.2 kg / 0,44 lbs

A dust cap should be used to prevent the ingress of dirt or water.

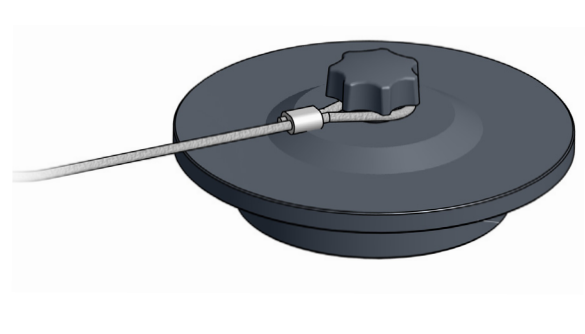

**Dust Plug (for HoseUnit)**

Code nr:	Material:	Weight:
I300A1101	Aluminium	0,4 kg / 0.88 lbs
I300A2201	Composite <sup>1)</sup>	0.2 kg / 0.44 lbs

A dust cap should be used to prevent the ingress of dirt or water.

<sup>1)</sup> Lowest operation temperature is -20° C / -4° F

## Technical Data

**Size of ISO45 DACoupling:** 2½" (DN 65)

**Materials:**

Aluminium

**Seals:**

FPM (Viton\*) or NBR (Nitrile) , Low temperature NBR, FQM (Flourosilicon)

\*) Viton is a registered trademark of DuPoint

**Lowest Operation Temperature :**

With Seals Material:	Lowest Temperature:
FPM (Standard Viton)	-20° C / -4° F
NBR	-25° C / -13° F
Low temperature NBR	-40° C / -40° F
FQM (Flourosilicon)	-55° C / -67° F

These materials must be tried individually and are subject to no obligation. Always check with chemical compability chart before use.

**Max Working Pressure:** 10 bar (150 psi)

**Test Pressure:** 15 bar (225 psi)

**Min. Burst Pressure:** 50 bar (750 psi)

**Safety Factor:** 5:1

**End Connections:** BSP- and NPT-threads, DIN- and ASA-flanges. Other connections on request.

No part of this leaflet may be reproduced in any form or by any means without permission in writing from the publisher.

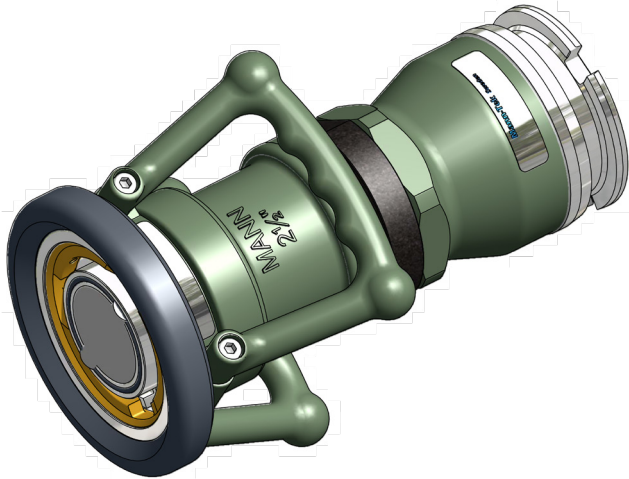

**2½" ISO45 Hose Unit to Tank Unit 3" (119 mm)<sup>1)</sup> STANAG 3756**



**3" (119 mm)<sup>1)</sup> Tank Unit STANAG 3756 to 2½" (105 mm)<sup>1)</sup> Hose unit**



The ISO45 coupling, in green colour, are also used for Military purposes with different adaptor systems.

**Connection adaptor:**

- 2½" ISO45 to 3" (119 mm)<sup>1)</sup> Tank Unit STANAG 3756.
- 2½" ISO45 to 3" (119 mm)<sup>1)</sup> TW EN14420-5
- 3" (119 mm)<sup>1)</sup> Hose Unit / Tank Unit STANAG 3756 to 3" (119 mm)<sup>1)</sup> TW EN14420- 5 Hose Unit / Tank Unit
- 3" (119 mm)<sup>1)</sup> Tank Unit STANAG 3756 to 2½" (105 mm)<sup>1)</sup> Hose Unit

The ISO45 Tank Unit are also available with pressure equalizing valve and pressure relief valve.

<sup>1)</sup> Connection 119 mm = 4.68 inch and 105 mm = 4.13 inch

**Examples of Military RAL colours**



**RAL 6014**  
Yellow Olive  
- Dutch Army



**RAL 6031**  
Bronze Green  
-Dutch, Germany, Denmark, Spain, Italy and Sweden.



**RAL 8027**  
Leather Brown  
- Germany



**RAL 9021**  
Tar Black  
- Germany

**Other colours on request**

*We can not guarantee that the colours above are correctly illustrated because print quality*

# Flange Measurement - 1/2

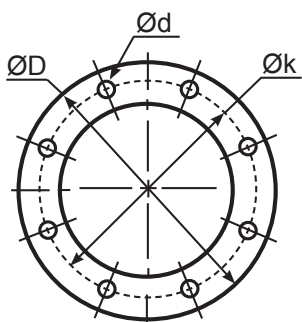

- Ø D = Diameter
- Ø k = Centre diameter
- n = Numer of holes
- Ø d = Hole diameter

## EN 1092-1

DN	PN 10				PN 16				PN 25				PN 40				
	ØD	Øk	n	Ød	ØD	Øk	n	Ød	ØD	Øk	n	Ød	ØD	Øk	n	Ød	
20	mm	105	75	4	14	105	75	4	14	105	75	4	14	105	75	4	14
	inch	4.13	2.95		0.55	4.13	2.95		0.55	4.13	2.95		0.55	4.13	2.95		0.55
25	mm	115	85	4	14	115	85	4	14	115	85	4	14	115	85	4	14
	inch	4.53	3.35		0.55	4.53	3.35		0.55	4.53	3.35		0.55	4.53	3.35		0.55
32	mm	140	100	4	18	140	100	4	18	140	100	4	18	140	100	4	18
	inch	5.51	3.94		0.71	5.51	3.94		0.71	5.51	3.94		0.71	5.51	3.94		0.71
40	mm	150	110	4	18	150	110	4	18	150	110	4	18	150	110	4	18
	inch	5.91	4.33		0.71	5.91	4.33		0.71	5.91	4.33		0.71	5.91	4.33		0.71
50	mm	165	125	4	18	165	125	4	18	165	125	4	18	165	125	4	18
	inch	6.50	4.92		0.71	6.50	4.92		0.71	6.50	4.92		0.71	6.50	4.92		0.71
65	mm	185	145	4	18	185	145	4	18	185	145	8	18	185	145	8	18
	inch	7.28	5.71		0.71	7.28	5.71		0.71	7.28	5.71		0.71	7.28	5.71		0.71
80	mm	200	160	8	18	200	160	8	18	200	160	8	18	200	160	8	18
	inch	7.87	6.30		0.71	7.87	6.30		0.71	7.87	6.30		0.71	7.87	6.30		0.71
100	mm	220	180	8	18	220	180	8	18	235	190	8	22	235	190	8	22
	inch	8.66	7.09		0.71	8.66	7.09		0.71	9.25	7.48		0.87	9.25	7.48		0.87
125	mm	250	210	8	18	250	210	8	18	270	220	8	26	270	220	8	26
	inch	9.84	8.27		0.71	9.84	8.27		0.71	10.63	8.66		1.02	10.63	8.66		1.02
150	mm	285	240	8	22	285	240	8	22	300	250	8	26	300	250	8	26
	inch	11.22	9.45		0.87	11.22	9.45		0.87	11.81	9.84		1.02	11.81	9.84		1.02
200	mm	340	295	8	22	340	295	12	22	360	310	12	26	375	320	12	30
	inch	13.39	11.61		0.87	13.39	11.61		0.87	14.17	12.20		1.02	14.76	12.60		1.18
250	mm	395	355	12	22	405	355	12	26	425	370	12	30	450	385	12	33
	inch	15.55	13.98		0.87	15.94	13.98		1.02	16.73	14.57		1.18	17.72	15.16		1.30
300	mm	445	400	12	22	460	410	12	26	485	430	16	30	515	450	16	33
	inch	17.52	15.75		0.87	18.11	16.14		1.02	19.09	16.93		1.18	20.28	17.65		1.30

## Flange translation EN 1092 ---- DIN

EN 1092-1	DIN
EN 1092-1 PN 6	DIN 2631
EN 1092-1 PN 10	DIN 2632
EN 1092-1 PN 16	DIN 2633
EN 1092-1 PN 25	DIN 2634
EN 1092-1 PN 40	DIN 2635
EN 1092-1 Type B Raised Face	DIN 2526 Form C
EN 1092-1 Type C Tongue	DIN 2512 Form F
EN 1092-1 Type D Groove	DIN 2512 Form N
EN 1092-1 Type E Spigot	DIN 2513 Form V
EN 1092-1 Type F Recess	DIN 2513 Form R

# Flange Measurement - 2/2

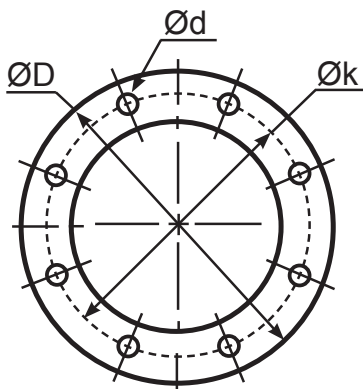

- Ø D = Diameter
- Ø k = Centre diameter
- n = Number of holes
- Ø d = Hole diameter

No part of this leaflet may be reproduced in any form or by any means without permission in writing from the publisher.

ANSI (ASA) B 16,5									
INCH		150 psi				300 psi			
		ØD	Øk	n	Ød	ØD	Øk	n	Ød
3/4"	mm	98,4	69,8	4	15,9	117,5	82,5	4	19
	inch	3 7/8	2 3/4		5/8	4 5/8	3 1/4		3/4
1"	mm	107,7	79,4	4	15,9	123,8	88,9	4	19
	inch	4 1/4	3 1/8		5/8	4 7/8	3 1/2		3/4
1 1/4"	mm	117,5	88,9	4	15,9	133,3	98,4	4	19
	inch	4 5/8	3 1/2		5/8	5 1/4	3 7/8		3/4
1 1/2"	mm	127	98,4	4	15,9	155,6	114,3	4	22,2
	inch	5	3 7/8		5/8	6 1/8	4 1/2		7/8
2"	mm	152,4	120,6	4	19	165,1	127	8	19
	inch	6	4 3/4		3/4	6 1/2	5		3/4
2 1/2"	mm	177,8	139,7	4	19	190,5	149,2	8	22,2
	inch	7	5 1/2		3/4	7 1/2	5 7/8		7/8
3"	mm	190,5	152,4	4	19	209,5	168,3	8	22,2
	inch	7 1/2	6		3/4	8 1/4	6 5/8		7/8
4"	mm	228,5	190,5	8	19	254	200	8	22,2
	inch	9	7 1/2		3/4	10	7 7/8		7/8
5"	mm	254	215,9	8	22,2	279,4	234,9	8	22,2
	inch	10	8 1/2		7/8	11	9 1/4		7/8
6"	mm	279,4	241,3	8	22,2	317,5	269,9	12	22,2
	inch	11	9 1/2		7/8	12 1/2	10 5/8		7/8
8"	mm	342,9	298,4	8	22,2	381	330,2	12	25,4
	inch	13 1/2	11 3/4		7/8	15	13		1
10"	mm	406,4	361,9	12	25,4	444,5	387,3	16	28,6
	inch	16	14 1/4		1	17 1/2	15 1/4		1 1/8
12"	mm	482,6	431,8	12	25,4	520,7	450,8	16	31,7
	inch	19	17		1	20 1/2	17 3/4		1 1/4

TW DIN 28459						
	DN	ØD	Øk	n	Ød	
TW1	50	mm	154	130	8	11
		inch	6.06	5.12		0.43
TW1	80	mm	154	130	8	11
		inch	6.06	5.12		0.43
TW3	100	mm	174	150	8	14
		inch	6.85	5.91		0.55
TW5	125	mm	204	176	8	14
		inch	8.03	6.93		0.55
TW7	150	mm	240	210	12	14
		inch	9.45	8.27		0.55

T.T.M.A					
INCH		ØD	Øk	n	Ød
2"	mm	114,3	95,3	6	11,1
	inch	4.50	3.75		0.44
3"	mm	142,9	123,8	8	11,1
	inch	5.63	4.87		0.44
4"	mm	168,3	149,2	8	11,1
	inch	6.63	5.87		0.44
5"	mm	196,9	177,8	12	11,1
	inch	7.75	7.00		0.44
6"	mm	228,6	206,4	12	11,1
	inch	9.00	8.13		0.44
8"	mm	276,2	257,2	16	11,1
	inch	10.87	10.13		0.44

## Mounting instruction

When installing Mann Tek equipment to new pipe work, tanks, etc. ensure the system is free from debris that may be transferred through the coupling. Where the hose or loading arm assembly is the primary static dissipation or earth route, the electrical continuity value of the assembly shall be checked to ensure regulatory compliance. Special attention should be paid to the balancing of loading arms. The weight of the coupling plus transfer media should be taken into account at the specification stage. It is usual for loading arm balance settings to account of weight variations due to differences in the full / empty cycle.

The loading arm should be set to balance in the condition present at the time of connection. For example, should the loading arm be empty at the time of connection then it should be balanced in the empty condition.

**The Mann-Tek product can be installed directly in the product line and is ready for use after removing the transport protection. The installation is recommended as follows:**

- Remove the packaging and the flange protection
- Check the coupling for damages before mounting.
- To prevent damages during mounting a suitable wrench should be used for the intended bolts and nuts.
- Ensure that the product line is empty and all valves are close before you connect the coupling into the line.
- Set in all bolts first and tighten them by hand. Then increase the tightening torque in 2 steps up to the recommended value in the following table. Proceed every time according to the sequence shown in g.
- Tightening torque<sup>1)</sup> for bolts:

Metric	
Size	8.8
M8	24 Nm
M10	50 Nm
M12	85 Nm
M16	210 Nm
M20	410 Nm
M22	550 Nm
M24	700 Nm

Inch	
Size	A193 B7
5/16 -18 UNC	16 lbf-ft
3/8 -16 UNC	29 lbf-ft
1/2 -13 UNC	70 lbf-ft
5/8 -11 UNC	139 lbf-ft
3/4 -10 UNC	243 lbf-ft
7/8 -9 UNC	389 lbf-ft
1 -8 UNC	582 lbf-ft

- Bolt tightening sequence.

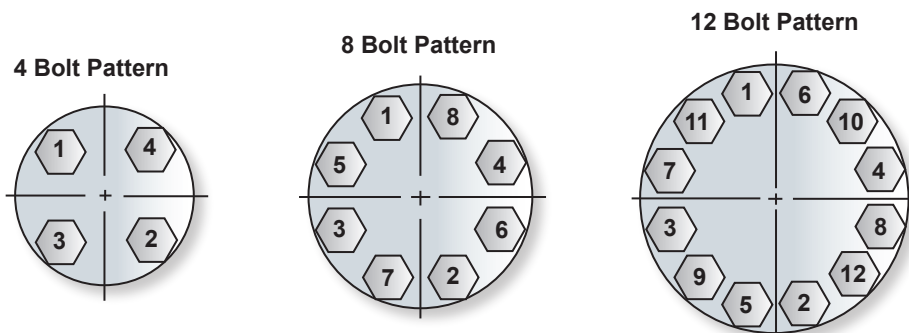

The start-up may take place only when the Mann-Tek product has been mounted as instructed and the necessary function tests and leak tests have been conducted by the approved authorities.

<sup>1)</sup> The torque forces recommended bases on a thread friction coefficient  $\mu=0,14$  and a standard flat seal according to EN 1514-1

## NPT

**Sealing NPT threads can be an exasperating experience if certain techniques are not followed. The following tips will help alleviate many common problems in thread sealing:**

1. Always use some type of sealant (tape or paste) and apply sealant to male thread only. If using a hydraulic sealant, allow sufficient curing time before system is pressurized.
2. When using tape sealant, wrap the threads in a clock-wise motion starting at the first thread and, as layers are applied, work towards the imperfect (vanishing) thread. If the system that the connection being made to cannot tolerate foreign matter (i.e. air systems), leave the first thread exposed and apply the tape sealant as outlined above.
3. When using paste sealant, apply to threads with a brush, using the brush to work the sealant into the threads. Apply enough sealant to fill in all the threads all the way around.
4. When connecting one stainless steel part to another stainless steel part that will require future disassembly, use a thread sealant that is designed for stainless steel. This stainless steel thread sealant is also useful when connecting aluminium to aluminium that needs to be disconnected in the future. These two materials gall easily, and if the correct sealant is not used, it can be next to impossible to disassemble.
5. When connecting parts made of dissimilar metals (i.e. steel and aluminium), standard tape or paste sealant performs satisfactory.
6. For sizes 2" and below, tape or paste performs satisfactory. When using thread tape, four wraps (covering all necessary threads) is usually sufficient.
7. For sizes 2½" and above, thread paste is recommended. If thread tape is used, eight wraps (covering all necessary threads) is usually sufficient. Apply more wraps if necessary.
8. For stubborn to seal threads, apply a normal coating of thread paste followed by a normal layer of thread tape.
9. For extremely stubborn to seal threads, apply a normal coating of thread paste followed by a single layer of gauze bandage followed by a normal layer of thread tape.

### Caution!

When this procedure is done, the connection becomes permanent. Extreme measures will be necessary to disconnect these components. All other measures to seal the threads should be explored prior to use of this technique.

10. Over-tightening threads can be just as detrimental as insufficient tightening. For sizes 2" and below, hand tighten the components and, with a wrench, tighten 3 full turns. For sizes 2½" and above, hand tighten the components and, with a wrench, tighten 2 full turns.

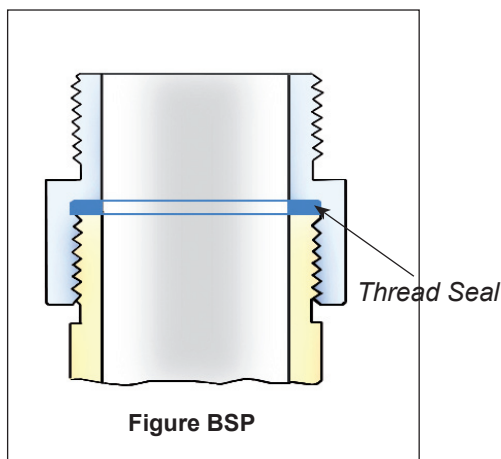
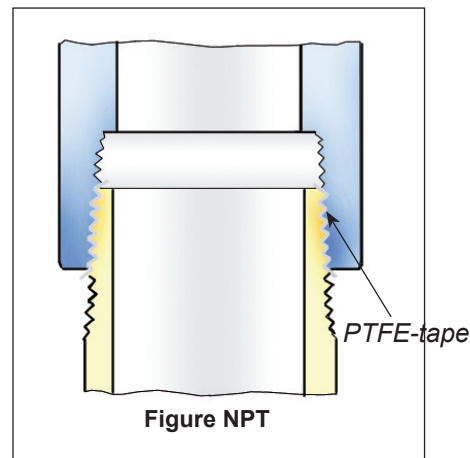

## BSP

The threads are parallel with flat sealing surface. This allows to use the full thread length for screwed-on parts. The largest possible transfer of force is guaranteed for short length. The thread seal behind the relief groove of the thread cannot drop out.

Simple screwing down, makes a safe connection. Subsequent tightening during operation is possible at any time. Change of seal and new assembly do not require any expert knowledge.

The European standardisations for hose assemblies require parallel threads with flat seals, because of the advantages.

# Flat Seals for thread - 1/2

weight ≈kg	Thread BSP	Materials Application	Dimensions ≈ mm			Product No
			D	d	s	
0,001	BSP 1/2"	PTFE ( Teflon®) white , massive continuously hard, universally resistant  Teflon® is a registered trademark of DuPont	20	13	2	On request
0,001	BSP 3/4"		26	19	2	1498-06
0,002	BSP 1"		33	24	2	1220-06
0,003	BSP 1 1/4"		42	34	2	1536-06
0,003	BSP 1 1/2"		48	39	2	1196-06
0,004	BSP 2"		60	49	2	1052-06
0,007	BSP 2 1/2"		76	63	2,5	1181-06
0,006	BSP 3"		88	77	3	1110-06
0,009	BSP 4"		114	100	3	1295-06
0,016	BSP 6"		164	150	3	1963-06
0,001	BSP 1/2"	Thermopac asbestos free, light hard. Especially for hot oils and hot bitumen up to 250° C and for hot water and saturated steam up to 25 bar.	20	13	2	On request
0,001	BSP 3/4"		26	19	2	1498-25
0,002	BSP 1"		33	24	2	1220-25
0,002	BSP 1 1/4"		42	34	2	1536-25
0,003	BSP 1 1/2"		48	39	2	1196-25
0,004	BSP 2"		60	49	2	1052-25
0,005	BSP 2 1/2"		76	63	3	1181-25
0,009	BSP 3"		88	77	3	1110-25
0,013	BSP 4"		114	100	3	1295-25
0,016	BSP 6"		164	150	3	1963-25
0,001	BSP 1/2"	FPM/FKM (Viton®) soft for aromatic hydrocarbons and hot oils.  Viton® is a registered trademark of DuPont	20	13	2	On request
0,001	BSP 3/4"		26	19	2	1498-01
0,002	BSP 1"		33	24	2	1220-01
0,002	BSP 1 1/4"		42	34	2	1536-01
0,003	BSP 1 1/2"		48	39	2	1196-01
0,004	BSP 2"		60	49	2	1052-01
0,006	BSP 2 1/2"		76	63	3	1181-01
0,008	BSP 3"		88	77	3	1110-01
0,014	BSP 4"		114	100	3	1295-01
0,016	BSP 6"		164	150	3	1963-01

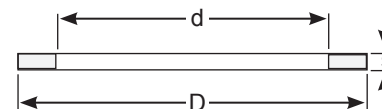

Bonded fibre material

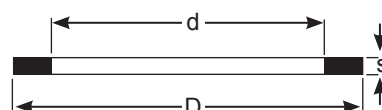
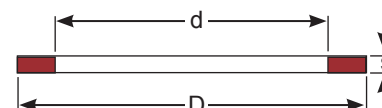

**Notice!** Seals are not included when you order flanges. You have to order Seals separately.

# Flat Seals for thread - 2/2

Standard sizes of PUR (VULKOLLAN® polyurethane elastomer), injection molded. Colour:blue.Other sizes of PUR (VULKOLLAN® Cast polyurethane). Colour: honey-coloured. **Vulkollan®** is a registered trademark of Bayer

Weight Appr. ≈ Kg	Suitable for	Dimensions ≈ mm			Product No
		D	d	s	
0,001	BSP 3/4"	26	19	2	1498-09
0,001	BSP 1"	33	24	2	1220-09
0,001	BSP 1 1/4" (DN 25 + DN 32)	42	34	2	1536-09
0,002	BSP 1 1/2" (DN 32 + DN 38)	48	39	2	1196-09
0,003	BSP 1 3/4"	54	44	2,5	On request
0,003	BSP 2"	60	49	2	1052-09
0,005	BSP 2 1/2"	76	63	2,5	1181-09
0,006	BSP 3"	88	77	3	1110-09
0,010	BSP 3 1/2"	100	80	3	On request
0,009	BSP 4"	114	100	3	1295-09
0,012	BSP 5" ( No standard)	140	124	3	On request
0,016	BSP 6"	164	150	3	1963-09

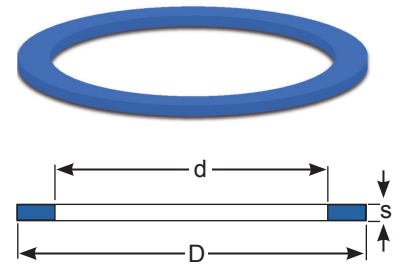

## ELAPAC Flange Seals FD, QFD

Flange Standard / Suitable for	Dimensions ≈ mm					Product No
	D	d	Øk	Øh	s	
DN 25 PN 10/16	108	78,5	91	4 x 6,5	2	-
DN 32 PN 10/16	140	43	100	4 x 18	2	-
DN 50 PN 6	140	61	110	4 x 15	2	-
DN 50 TW 1	154	50	130	8 x 12	2	-
DN 80 TW 1	154	90	130	8 x 12	2	-
DN 50 PN 10/16	165	61	125	4 x 18	2	-
DN 100 TW3	174	110	150	8 x 14	2	-
DN 65 PN 10/16	185	76	145	4 x 18	2	-
DN 80 PN 10/16	200	90	160	8 x 18	2	-
DN 125 TW5	204	135	176	8 x 14	2	-
DN 100 PN 10/16	220	115	180	8 x 18	2	-
DN 150 TW7	240	160	210	12 x 14	2	-
DN 125 PN 10/16	250	141	210	8 x 18	2	-
DN 150 PN 10/16	280	169	240	8 x 22	2	-
DN 200 PN 10	340	220	295	8 x 22	2	-
DN 200 PN 16	340	220	295	12 x 22	2	-

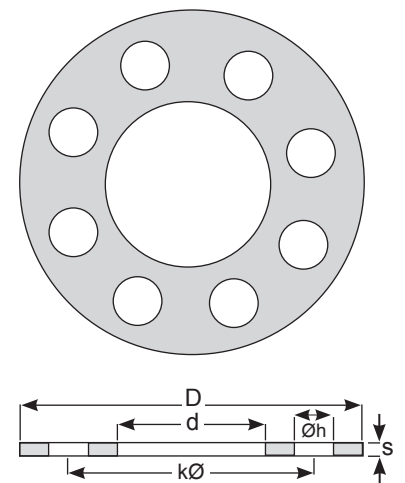

**Notice!** Seals are not included when you order flanges. You have to order Seals separately.



# Explanation of Designations - 1/2

Ver 1301

## First sign (letter): Indicates the type of coupling

A = API-adaptor  
 AV = Tank Unit (EN 13081)  
 B = Ball Valve  
 C = Dust Cap  
 CG = Dust Cap LPG  
 D = Swivel  
 E = Tank Unit with pressure valves  
 F = Hose Unit (ISO 45)  
 G = Tank Unit (ISO 45)  
 GS = Tank Unit (ISO 45) with selectivity

H = Sampling Vent & Drain Unit  
 I = Dust Plug ISO 45  
 K = Dust Cap ISO 45  
 L = Tank Unit LPG  
 LC = Tank Unit Cryogenic  
 M = Hose Unit LPG  
 MC = Hose Unit Cryogenic  
 N = Break Away Pin  
 NC = Break Away Pin Cryogenic  
 O = Break Away Wire

P = Dust Plug  
 R = Pressure Cap  
 RG = Pressure Cap LPG  
 S = Hose Unit (STANAG 3756)  
 SN = Hose Unit int. Break Away Pin  
 SO = Hose Unit int. Break Away Wire  
 T = Tank Unit (STANAG 3756)  
 U = Filter / Sight Glass  
 V = Dust Plug LPG  
 WA = Hose Fittings

## Second sign (numeral): Indicates the socket diameter and/or the nominal diameter

0 = 50mm or 3/4"  
 1 = 56mm or 1", 1 1/4"  
 2 = 70mm or 1 1/2", 2"  
 3 = 105mm or 2 1/2"

4 = 119mm or 3"  
 5 = 164mm or 4"  
 V = 5"  
 6 = 238mm or 6"

8 = 272mm or 8"  
 10 = 10"  
 12 = 12"

## Third and fourth sign (numeral): Indicates connection, (thread, flange etc.)

01 = 3/4" BSP (Female)  
 02 = 3/4" NPT (Female)  
 03 = 1" BSP (Female)  
 04 = 1" NPT (Female)  
 05 = 1 1/4" BSP (Female)  
 06 = 1 1/4" NPT (Female)  
 07 = 1 1/2" BSP (Female)  
 08 = 1 1/2" NPT (Female)  
 09 = 1 3/4" BSP (Female)  
 10 = 2" BSP (Female)  
 11 = 2" NPT (Female)  
 12 = 2 1/2" BSP (Female)  
 13 = 2 1/2" NPT (Female)  
 14 = 3" BSP (Female)  
 15 = 3" NPT (Female)  
 16 = 4" BSP (Female)  
 17 = 4" NPT (Female)  
 18 = Flange undrilled Ø156  
 19 = Flange undrilled Ø165  
 20 = Flange undrilled Ø210  
 21 = Flange undrilled Ø230  
 22 = Flange undrilled Ø254  
 23 = Flange DN 25 PN 10/16  
 24 = Flange DN 25 PN 25/40  
 25 = Flange DN 32 PN 10/16  
 26 = Flange DN 32 PN 25/40  
 27 = Flange DN 40 PN 10/16  
 28 = Flange DN 40 PN 25/40  
 29 = Flange DN 50 PN 25/40\*  
 30 = Flange DN 50 PN 10/16  
 31 = Flange DN 50 PN 25/40  
 32 = Flange DN 65 PN 25/40\*  
 33 = Flange DN 65 PN 10/16  
 34 = Flange DN 65 PN 25/40  
 35 = Flange DN 80 PN 25/40\*  
 36 = Flange DN 80 PN 10/16  
 37 = Flange DN 80 PN 25/40  
 38 = Flange DN 100 PN 25/40\*  
 39 = Flange DN 100 PN 10/16  
 40 = Flange DN 100 PN 25/40  
 41 = Flange DN 125 PN 6  
 42 = Flange DN 125 PN 10/16  
 43 = Flange DN 125 PN 25/40  
 44 = Flange DN 150 PN 6  
 45 = Flange DN 150 PN 10/16  
 46 = Flange DN 150 PN 25/40  
 47 = Flange DN 20 PN 10/16  
 48 = Flange DN 20 PN 25/40  
 49 = Flange 3/4" ANSI Class 150  
 50 = Flange 3/4" ANSI Class 300  
 51 = Flange 1" ANSI Class 150  
 52 = Flange 1" ANSI Class 300  
 53 = Flange 1 1/4" ANSI Class 150  
 54 = Flange 1 1/4" ANSI Class 300  
 55 = Flange 1 1/2" ANSI Class 150  
 56 = Flange 1 1/2" ANSI Class 300  
 57 = Flange 2" ANSI Class 150  
 58 = Flange 2" ANSI Class 300  
 59 = Flange 2 1/2" ANSI Class 150  
 60 = Flange 2 1/2" ANSI Class 300  
 61 = Flange 3" ANSI Class 150  
 62 = Flange 3" ANSI Class 300  
 63 = Flange 4" ANSI Class 150  
 64 = Flange 4" ANSI Class 300  
 65 = Flange TW 1 (3" - DN 80)  
 66 = Flange TW 3 (4" - DN 100)  
 67 = Flange 3" T.T.M.A.  
 68 = Flange 4" T.T.M.A.  
 69 = 3/4" BSP (Male)  
 70 = 3/4" NPT (Male)  
 71 = 1" BSP (Male)  
 72 = 1" NPT (Male)  
 73 = 1 1/4" BSPT (Male)

74 = 1 1/4" NPT (Male)  
 75 = 1 1/2" BSP (Male)  
 76 = 1 1/2" NPT (Male)  
 77 = 1 3/4" BSP (Male)  
 78 = 2" BSP (Male)  
 79 = 2" NPT (Male)  
 80 = 2 1/2" BSP (Male)  
 81 = 2 1/2" NPT (Male)  
 82 = 3" BSP (Male)  
 83 = 3" NPT (Male)  
 84 = 4" BSP (Male)  
 85 = 4" NPT (Male)  
 86 = Weld.flange 2" Ø60,5 inner  
 87 = Flange TW 1 (2" DN50)  
 88 = Weld.flange 2" Ø50-Ø70 (flat)  
 89 = Weld.flange 2" Ø57 (int. chamfer)  
 90 = Weld.flange 2" Ø60 (outer chamfer)  
 91 = Weld.flange 3" Ø75-Ø90 (flat)  
 92 = Weld.flange 3" Ø76 (int. chamfer)  
 93 = Weld.flange 3" Ø89 (outer. chamfer)  
 94 = Weld.flange 4" Ø100-Ø120 (flat)  
 95 = Weld.flange 4" Ø102 (int. chamfer)  
 96 = Weld.flange 4" Ø108 (int. chamfer)  
 97 = Weld.flange 4" Ø114 (outer. chamfer)  
 98 = Flange TW 1 (2" - DN 50) with drain connection  
 99 = Flange DN 150 PN 25  
 100 = Flange 6" ANSI Class 150  
 101 = Flange 6" ANSI Class 300  
 102 = Flange DN 200 PN 10  
 103 = Flange DN 200 PN 16  
 104 = Flange DN 200 PN 25  
 105 = Flange 8" ANSI Class 150  
 106 = Flange 8" ANSI Class 300  
 107 = Flange Square ISO 45  
 108 = S60x6 (Female)  
 109 = S60x6 (Male)  
 110 = 6" BSP (Female)  
 111 = 6" NPT (Female)  
 112 = W2" - 7 (Female)  
 113 = Weld.flange 3" Ø92 inner  
 114 = Square flange, 4 holes  
 115 = 6" BSP (Male)  
 116 = 6" NPT (Male)  
 117 = 8" NPT (Female)  
 118 = 4" Victaulic  
 119 = Flange DN 50 PN 25/40\*\*  
 120 = Flange DN 65 PN 25/40\*\*  
 121 = Flange DN 80 PN 25/40\*\*  
 122 = Flange DN 100 PN 25/40\*\*  
 123 = W2" - 7 (Male)  
 124 = 5" NPT (Female)  
 125 = 5" NPT (Male)  
 126 = Flange DN 100 PN6  
 127 = Flange DN 80 PN6  
 128 = Flange DN 65 PN6  
 129 = Flange DN 50 PN6  
 130 = Flange 8" ANSI Class 600  
 131 = W90x1/6" (Female)  
 132 = 1/2" NPT (Female)  
 133 = 1/2" BSP (Female)  
 134 = Flange Ø184,2, 6 holes  
 135 = Flange TW 7 (6" - DN 150)  
 136 = 4" ASSPT (Female)  
 137 = Triclamp DN 25  
 138 = M54x 1,5 (Female)  
 139 = Triclamp DN 50  
 140 = Weld.flange Ø73 (outer chamfer)  
 141 = 3" Victaulic  
 142 = Flange 5" ANSI Class 150  
 143 = 3" Ball valve  
 144 = 2" Victaulic  
 145 = 3" BSPT (Male)

146 = 5" Victaulic  
 147 = 2" BSPT (Female)  
 148 = 2" BSPT (Male)  
 149 = 1 1/2" Victaulic  
 150 = 2 1/2" Victaulic  
 151 = Flange 1" DIN 11864-2  
 152 = Flange 2" DIN 11864-2  
 153 = Flange Ø135, 8xM6  
 154 = 4" BSPT (Female)  
 155 = 4" BSPT (Male)  
 156 = Weld flange 2" Ø61,5 (inner)  
 157 = 3" BSPT (Female)  
 158 = Weld end 1 1/2" Ø48 (outer)  
 159 = Thread TR 57x4  
 160 = Flange 2" BS10 Table D  
 161 = Flange 12" ANSI Class 150  
 162 = Flange 10" ANSI Class 150  
 163 = Flange DN 250 PN 16  
 164 = M130x6 (Female)  
 165 = Flange 10" ANSI Class 300  
 166 = ACME 1 1/4" (Female)  
 167 = ACME 1 1/4" (Male)  
 168 = ACME 2 1/4" (Female)  
 169 = ACME 3 1/4" (Female)  
 170 = ACME 1 1/4" (Male)  
 171 = ACME 1 3/4" (Male)  
 172 = ACME 2 1/4" (Male)  
 173 = ACME 3 1/4" (Male)  
 174 = Weld.flange Ø76 (outer. chamfer)  
 175 = Flange DN 15 PN 10/16  
 176 = Flange DN 15 PN 25/40  
 177 = M130x6 (Male)  
 178 = Flange 6" T.T.M.A.  
 179 = Flange DN 80 PN 25/40\*\*\*  
 180 = 1/2" NPT (Male)  
 181 = 1/2" BSP (Male)  
 182 = 5" BSP (Female)  
 183 = 5" BSP (Male)  
 184 = Weld end 8" Ø219 (outer)  
 185 = Weld end 6" Ø168 (outer)  
 186 = Flange DN 250 PN 25  
 187 = Flange 2" T.T.M.A.  
 188 = Flange 3" BS10 Table D  
 189 = Flange 1/2" ANSI Class 150  
 190 = Flange 1" ANSI Class 150 Flat Face  
 191 = Flange 12" ANSI Class 300  
 192 = Flange DN250 PN10  
 193 = Weld end Ø114 Schedule 40  
 194 = Weld end Ø114 Schedule 80  
 195 = 6" Victaulic  
 196 = 1" Victaulic  
 197 = DN 125 JIS 5K  
 198 = DN 100 JIS 5K  
 199 = DN 80 JIS 5K  
 200 = DN 50 JIS 5K  
 201 = DN 40 JIS 5K  
 202 = Flange 2" DIN 11864-3  
 203 = 3 1/2" BSP (Female)  
 204 = Flange Ø110, Ø86/Ø5.5 (6x)  
 205 = Weld end Ø60 Schedule 80  
 206 = Weld end Ø89 Schedule 40  
 207 = Weld end Ø89 Schedule 80  
 208 = Flange DN 25 PN 6  
 209 = Flange DN 32 PN 6  
 210 = Flange DN 40 PN 6  
 211 = DN 125 JIS 10K  
 212 = DN 100 JIS 10K  
 213 = DN 80 JIS 10K  
 214 = DN 50 JIS 10K  
 215 = DN 40 JIS 10K  
 216 = Flange DN 80, holes Ø14 (6x)  
 217 = Flange 5" ANSI Class 300

\* EN 1092-1:2001 Type E: Spigot

\*\* EN 1092-1:2001 Type F

\*\*\* EN 1092-1:2001 Type C

No part of this leaflet may be reproduced in any form or by any means without permission in writing from the publisher

**NOTE!** When swivels are chosen, the second and the third sign indicates one outlet, the fourth and the fifth sign the second outlet.

No part of this leaflet may be reproduced in any form or by any means without permission in writing from the publisher.

## Fifth sign (letter): Indicates version

A = Version No.1 (Machined from bar)	G = Drain connection	P = Pressure (Custom)
B = Version No.2 (Casted)	H = Leaf spring lock	S = Sight Glass
C = Version No.3 (Kokill casted)	I = Bended Tank Unit Short (15°)	T = Transparent
D = Sep. piston guide	J = Bended Tank Unit (15°)	U = Stop before disconnected
E = Injection moulded	K = Short Tank Unit/Swivel	
F = 6" Flange Hydrant	N = Non Return Valve	

## Sixth sign (numeral): Indicates material in the coupling body

1 = Aluminium	6 = Titan
2 = Brass	7 = Hastelloy
3 = Steel	8 = PVDF
4 = Stainless steel A4 (316)	9 = PEEK
5 = Stainless steel A2 (304)	K = Inconel

## Seventn sign (numeral): Indicates material in the innerparts or other components

1 = Aluminium	6 = Titan
2 = Brass	7 = Hastelloy
3 = Steel	8 = PVDF
4 = Stainless steel A4 (316)	9 = PEEK
5 = Stainless steel A2 (304)	K = Inconel

## Eight and Ninth sign (numeral): Indicates the O-ring material in the coupling

01 = Viton® (FPM/FKM)	16 = Hypalon® (CSM)	37 = Chemraz® 510 (90 Shore)
02 = Nitrile (NBR)	17 = Chemraz® 505 (FFKM)	40 = FEP PTFE encapsulated Viton®
03 = EPDM	18 = Xyflour® 860 (AFKM)	50 = Kalrez® (PFPM) 1050LF
04 = Kalrez® (FFKM) 6375	19 = Zetpol® / Therban® (HNBR)	51 = Nylon® (PA)
05 = NBR Low temp	20 = NBR 90 shore	61 = Viton® (FPM), FDA, USP C6 & ADI
06 = Teflon® (PTFE)	21 = Viton®-GF (Special Viton quality)	62 = Nitrile (NBR), FDA, USP C6 & ADI
07 = Neoprene® (CR)	22 = Composite	63 = EPDM, FDA, USP C6 & ADI
08 = Silicone (Q)	23 = Viton® GFLT-S	64 = Kalrez® (FFKM) 6230, FDA, USP C6 & ADI
09 = Vulkollan® (PUR)	24 = Viton® GLT	66 = PTFE (Virgin), FDA
10 = Butyl (IIR)	25 = Klingerit®	71 = FPM/FKM Low Temp
11 = Nitrile (Gasol NBR 70 K-6)	26 = POM	77 = Chemraz® SD517, FDA, USP C6 & ADI
12 = Perfluorelastomer (FFPM/FFKM)	27 = Epiclорhydrin (ECO)	83 = EPDM BAM
13 = PVC / NBR	28 = Viton® GFLT-S NMO	
14 = Fluorsilicone rubber (MFQ)	31 = Viton® 90 Shore (FPM/FKM)	
15 = FEP encapsulated silicone	33 = EPDM 291	
	34 = Kalrez® 0040	

## Tenth sign (letter): Used for extra

A = Flat seal, Teflon®(PTFE)	M = Modified Cam Curve	V = Locking house unit
B = Flat seal, Vulkollan®(PUR)	N = No Branding	W = Double ball race
C = 2-way Ball Valve	NA = No Actuator (Ball Valve)	X = Special surface treatment
D = Flat seal, Viton® (FPM)	P = Pressure Equalizing Valve	Z = Excentric tank unit
DA = Double Acting (Ball Valve)	Q = Reduced bore diameter (Argus,Hydrant)	-RA = Racing
E = None projecting piston spindle	R = Hose unit with int. Break Away	-LC = Locking Cap
F = Flange thickness acc. to standard	S = Single Argus valve (Hydrant)	-S = FEP O-ring in Hose Unit swivel
G = Hypalon	SR = Spring Return (Ball Valve)	-ST = Steam
H = Nitrile (NBR)	T = TW-Flange extended circles	-XL = Oversized swivel
I = Emco comp	U = Pressure Bleeding Valve 16 bar	-45 = 45 Mesh
J = EPDM	U5 = Pressure Bleeding valve 5 bar	-60 = 60 Mesh
K = Locked piston guide	U20 = Pressure Bleeding valve 20 bar	-10 = 100 Mesh
L = Locked thread		

No part of this leaflet may be reproduced in any form or by any means without permission in writing from the publisher.

No part of this leaflet may be reproduced in any form or by any means without permission in writing from the publisher.

Design may change without notice

©Mann Teknik 2013

Selection of registered trade names from Messrs BASF, Bayer AG, B.F. Goodrich, Chemische Werke Hüls, Daikin, Dow Company, DSM, Du Pont, DuPont Dow Elastomers, Esso Chemie, Hercules, Hoechst AG, Montedison, Monteflous, Nippon Zeon, Polysar LTD., Rhone Poulenc, 3 M Company, Wacker Chemie, Precision Polymer Engineering Ltd.



Date	Name
Title	Company
Department	Address
Country	Telephone
E-mail	Fax

## Product data

Code No.	Quantity
Internal diameter:	Connection:
Product type/spec/options:	
Size <input type="text"/>	Integrated Breakaway <input type="checkbox"/> Pressure releafe valve <input type="checkbox"/>
Other options :	
Material	
Other remarks	
Pressure certificate <input type="checkbox"/>	Material Certificate 3.1 <input type="checkbox"/>

## Flow data (Media Cast No)

## Cleaning process

1	⋮		
2	⋮		
3	⋮		
4	⋮		
5	⋮		
Working Pressure	Temperature	Concentration	Vacuum

## Customers note

--

No part of this leaflet may be reproduced in any form or by any means without permission in writing from the publisher.

## About

Mann Tek is a Swedish manufacturer and supplier of Safety breakaway couplings with experience of the industry for more than 20 years. We supply modern, easy to use, safe and timesaving products. A environmentally safe system for both staff and its surroundings, which prevents a variety of hazards. Our products are the obvious choice in harsh and demanding environments and where there's a need of a safe and spill free handling of fluids, gases and bulk powders. With more than twenty years of knowledge and experience of multiply industries it has accumulated extensive expertise about applications in many types of variations in which our couplings have been, and can be used, with excellent results.



We constantly strive to develop and improve the performance and design of our products, to meet changes, new market demands and standards. Which, today, is what made us market leading.

Our couplings are the obvious choice when certifications and product approvals are required, anywhere in the world.

Mann Tek® is certified to ISO9001:2008 and the products are produced in accordance with several important standards, e.g. the NATO STANAG 3756, NATO STANAG 3105, ISO 45, MS24484, British Aerospace Specification 2C14

## Company Approvals



Mann-Tek is a certified ISO9001-company.