

# *Swivels*

## **Swivel Joints**



# Product Information

# Introduction

## Swivels

Swivel Joints are used in the industry wherever a movable pipe-connection system between two equipment parts is needed. Avoiding one of the biggest causes of premature hose failure. Torque stress is the largest single cause of PTFE and Stainless steel convoluted hose failure.

The swivel joints are designed for slow rotary motions under the influence of high internal pressures and/or external stress such as traction and bending forces.

With an appropriate combination of swivel joints nearly all movements from the simple rotation or swivelling motion up to motional actions in space can be realized.

## Table of content

<b>Content</b>	<b>Page</b>
About NPT and BSP threads	12
Article no.	7
Flange connection	11
Flange facing types according to EN 1092	8
Flange Measurement	9-10
Seals	13-14
Heavy Duty Swivels - double ball race	5-6
Hose Swivels - single ball bearing	3-4
O-ring materials	15

# Hose Swivels - single ball bearing

## Use of Hose Swivels

The use of hose swivel avoids torsion of hose assemblies, i.e. in filling machines, and improves the handling and coupling of nozzles for refuelling of petroleum based products and chemicals.

## Applications

- Hose assemblies
- Filling machines
- Handling of refuelling of equipment e.t.c.



### NOTE

**Unsuitable for high bending moments. Heavy Duty Swivels should be used in these applications.**

- **Low maintenance**  
Each unit consist of two body halves. Stainless Steel balls and a single spring assisted O-ring seal.
- **Compact external dimensions**
- **High flow rate / low pressure drop**
- **Full range of sizes, materials, seals and connections**
- **Minimal maintenance requirements**
- **Safety**  
Swivel function - allows the hose to relax to it's natural rest position whilst allowing freedom of movement without imparting torque stress at the point of connection - Torque stress is the largest single cause of Composite, PTFE and Stainless Steel convoluted hose failure.
- **Economical**  
Cost effective solution to prolong lifetime of hose-lines.

## Mann Tek standard Hose Swivel

Standard Flat seal (for BSP threads and body in Stainless Steel) in PTFE (Teflon®). Other on request!

Standard O-rings in FPM (Viton®). Other on request!

Available with parallel BSP and tapered NPT threads.

Available with parallel BSP and tapered NPT threads.

Swivel body in Aluminium, Brass or Stainless Steel. Other on request!

Ballbearings in Stainless Steel

Wavy washer in Stainless Steel

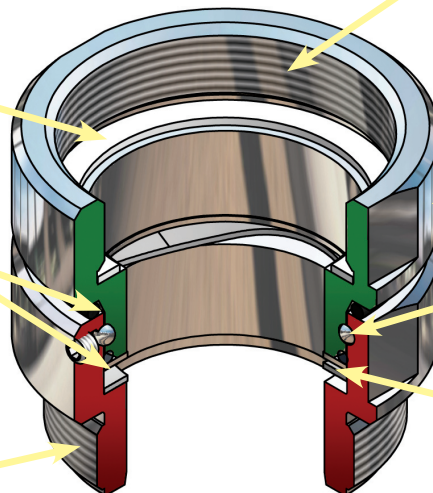

# Hose Swivels - single ball bearing

## Combinations of sizes, connections and materials

### Sizes

Swivel sizes							
3/4"	1"	1 1/4"	1 1/2"	2"	2 1/2"	3"	4"

### Connections

Threads (Female / Male <sup>1)</sup> )
BSP (ISO 228)
NPT (ASME/ANSI 1.20.1)
BSPT (EN 10226)
ACME
Weld end

Flanges
DIN Flange (ISO 1092 PN 10/16, PN 25/40 (Type A, B, E, F <sup>2</sup> )
ASA Flange (ASME/ANSI 16.5)
TW-Flange (DIN 28459)
T.T.M.A

<sup>1)</sup> Any combinations of male and female threads is possible.

<sup>2)</sup> See page 14 for illustrations of different types of DIN-flanges

### Materials and Seals

Standard Materials and standard Seals					
Component	Material	Material Standard	Operation temp	O-ring	Flat Seal
Body	Aluminium	EN 755 - AW-6262-T6	-40°C to 250°C	FPM/KFM (Viton®)	PUR (Vulkollan®)
		EN 1706-AC-42100-T6			PUR (Vulkollan®)
	Brass	EN 12164 - CW614N			PTFE (Teflon®)
		EN 1982 - CB491K-GS			
	Stainless Steel	EN 10272 - 1.4404+AT			
		EN 10213 - 1.4409+AT			

Working Pressure: (10 bar) - 300 psi (20 bar)

### Illustrations of combinations

We manufacture Swivels in different sizes, connections and materials on request!

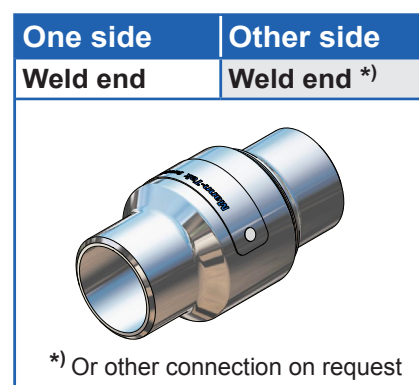
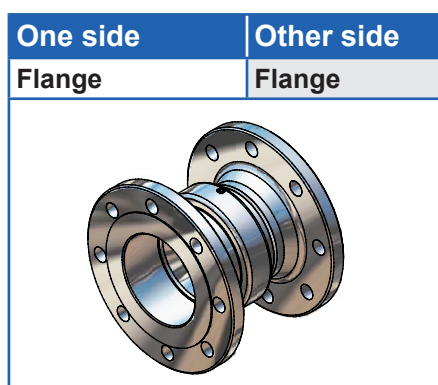
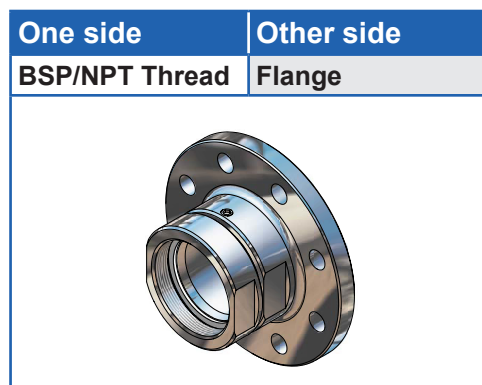
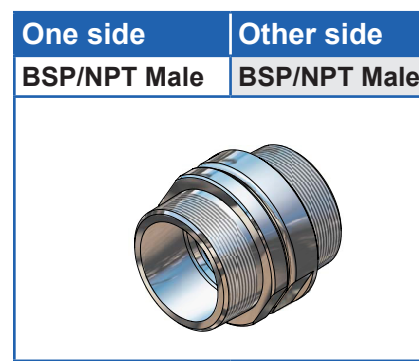
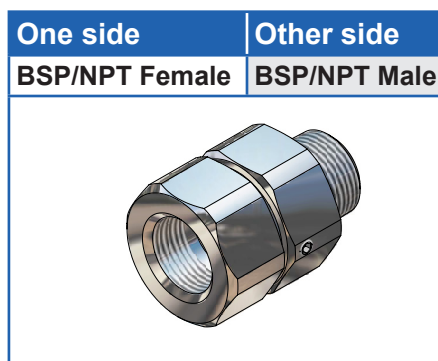
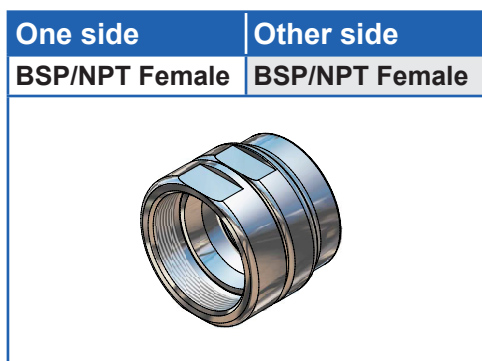

Viton® and Teflon® are registered trademarks of DuPont, DuPont Elastomers. Vulkollan® is registered trademark of Bayer AG

ООО «ТИ-СИСТЕМС» ИНЖИНИРИНГ И ПОСТАВКА ТЕХНОЛОГИЧЕСКОГО ОБОРУДОВАНИЯ

Интернет: [www.tisys.ru](http://www.tisys.ru) [www.tisys.kz](http://www.tisys.kz) [www.tisys.by](http://www.tisys.by) [www.tesec.ru](http://www.tesec.ru) [www.ти-системс.рф](http://www.ти-системс.рф)

Телефоны: +7 (495) 7774788, 7489626, (925) 5007155, 54, 65

Эл. почта: [info@tisys.ru](mailto:info@tisys.ru) [info@tisys.kz](mailto:info@tisys.kz) [info@tisys.by](mailto:info@tisys.by)

# Heavy Duty Swivels - double ball race

## Use of Heavy Duty Swivel - double ball race

The swivel Heavy duty is designed especially for hose rails to load and unload products like Aliphatic and Aromatic hydrocarbons, Alcohols and Amines, Ether and Ester, Glycos and Water, Liquid Fertilizers, Acids and Lyes.

### NOTE

*Please ask us for your special application.*

## Applications

- Offshore hose reels ship-to-shore
- Oil platform loading rigs
- Marine and industrial loading arms
- Hoses for road and rail tanker
- Chemical and petrochemical liquids and liquefied gases



- **Low maintenance**  
Each unit consist of two body halves. Stainless Steel balls and a single spring assisted O-ring seal.
- **Compact external dimensions**
- **High flow rate / low pressure drop**
- **Full range of sizes, materials, seals and connections**
- **Minimal maintenance requirements**
- **Safety**  
Swivel function - allows the hose to relax to it's natural rest position whilst allowing freedom of movement without imparting torque stress at the point of connection - Torque stress is the largest single cause of Composite, PTFE and Stainless Steel convoluted hose failure.
- **Economical**  
Cost effective solution to prolong lifetime of hoses.

## Heavy duty Swivel in Stainless Steel

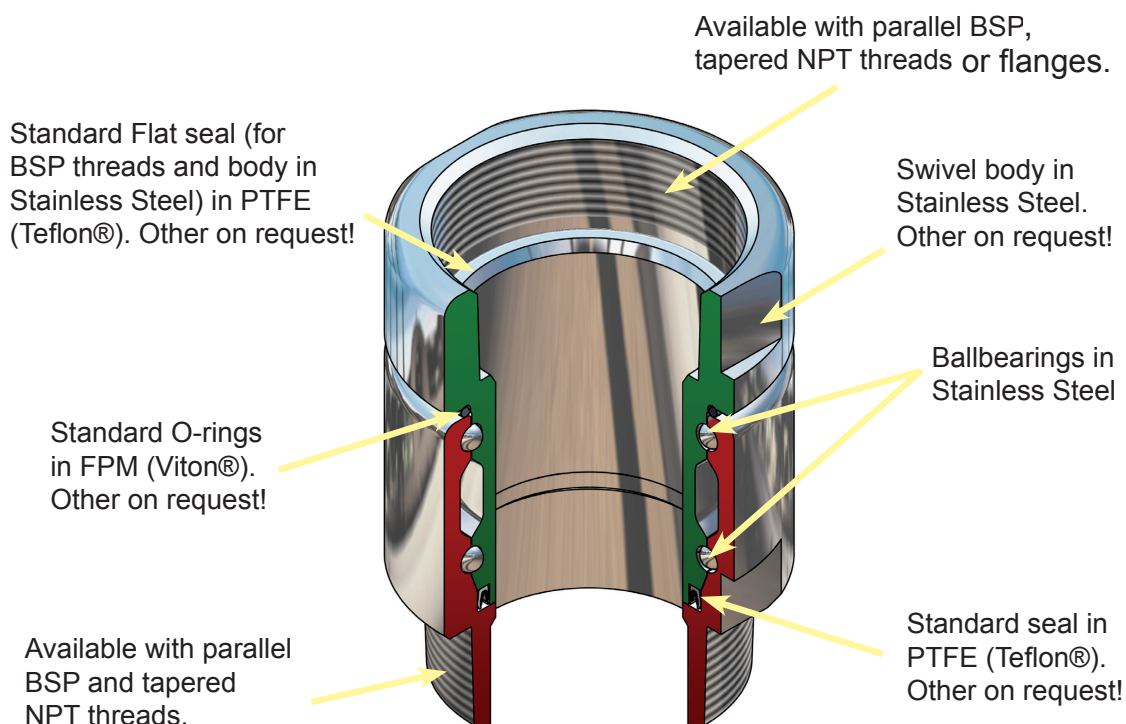

ООО «ТИ-СИСТЕМС» ИНЖИНИРИНГ И ПОСТАВКА ТЕХНОЛОГИЧЕСКОГО ОБОРУДОВАНИЯ

Интернет: [www.tisys.ru](http://www.tisys.ru) [www.tisys.kz](http://www.tisys.kz) [www.tisys.by](http://www.tisys.by) [www.tesec.ru](http://www.tesec.ru) [www.ти-системс.рф](http://www.ти-системс.рф)

Телефоны: +7 (495) 7774788, 7489626, (925) 5007155, 54, 65

Эл. почта: [info@tisys.ru](mailto:info@tisys.ru) [info@tisys.kz](mailto:info@tisys.kz) [info@tisys.by](mailto:info@tisys.by)

# Heavy Duty Swivels - double ball race

## Combinations of sizes, connections and materials

### Sizes

Swivel sizes						
2"	3"	4"	5"	6"	8"	10"

### Connections

Threads (Female / Male <sup>1)</sup> )	Flanges
BSP (ISO 228)	DIN Flange (ISO 1092 PN 10/16, PN 25/40 (Type A, B, E, F <sup>2)</sup> )
NPT (ASME/ANSI 1.20.1)	ASA Flange 150 psi / 300 psi (ASME/ANSI 16.5)
BSPT (EN 10226)	TW-Flange (DIN 28459)
ACME	T.T.M.A
Victaulic	
Weld end	

<sup>1)</sup> Any combinations of male and female threads is possible.

<sup>2)</sup> See page 14 for illustrations of different types of DIN-flanges



### Materials and Seals

Standard Materials and standard Seals						
Component	Material	Material Standard	Operation temp	Seal	Flat Seal	
Body	Aluminium	EN 755 - AW-6262-T6	-100°C to 250°C	PTFE (Teflon®)	PUR (Vulkollan®)	
		EN 1706-AC-42100-T6			PTFE (Teflon®)	
	Stainless Steel	EN 10272 - 1.4404+AT				
		EN 10213 - 1.4409+AT				

Working Pressure: 150 psi (10 bar)-1800 psi (125 bar)

### Illustrations of combinations

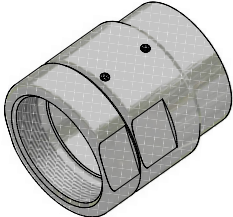
*We manufacture Swivels in different sizes, connections and materials on request!*

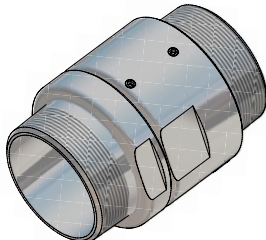
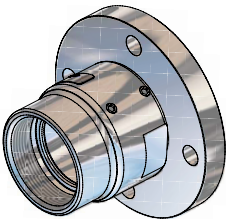
One side	Other side	One side	Other side	One side	Other side	One side	Other side
BSP/NPT F	BSP/NPT F	BSP/NPT F	BSP/NPT M	BSP/NPT M	BSP/NPT M	Thread	Flange
							

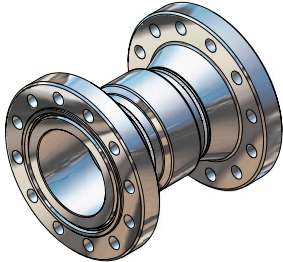
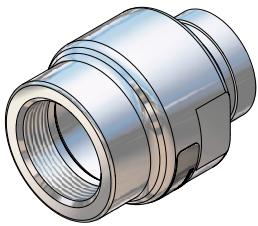
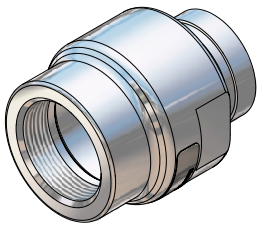
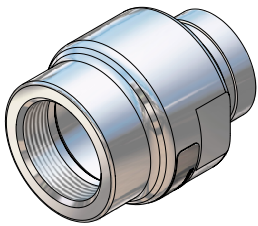
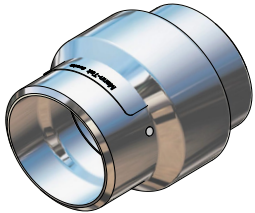
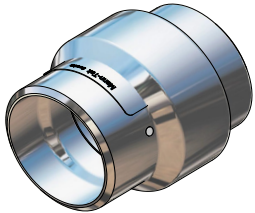
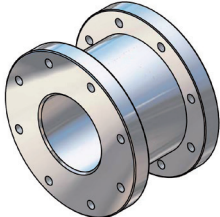
One side	Other side	One side	Other side	One side	Other side	Compact version
Flange	Flange	Victaulic	Victaulic <sup>*)</sup>	Weld end	Weld end <sup>*)</sup>	
						
		*) Or other connection on request		*) Or other connection on request		

Viton® and Teflon® are registered trademarks of DuPont, DuPont Elastomers. Vulkollan® is registered trademark of Bayer AG

ООО «ТИ-СИСТЕМС» ИНЖИНИРИНГ И ПОСТАВКА ТЕХНОЛОГИЧЕСКОГО ОБОРУДОВАНИЯ

Интернет: [www.tisys.ru](http://www.tisys.ru) [www.tisys.kz](http://www.tisys.kz) [www.tisys.by](http://www.tisys.by) [www.tesec.ru](http://www.tesec.ru) [www.ти-системс.рф](http://www.ти-системс.рф)

Телефоны: +7 (495) 7774788, 7489626, (925) 5007155, 54, 65

Эл. почта: [info@tisys.ru](mailto:info@tisys.ru) [info@tisys.kz](mailto:info@tisys.kz) [info@tisys.by](mailto:info@tisys.by)



# Flange facing types according to EN 1092

**Type A Flat face**

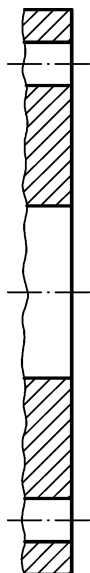

**Type B Raised face**

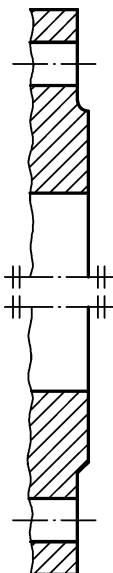

**Type C Tongue**

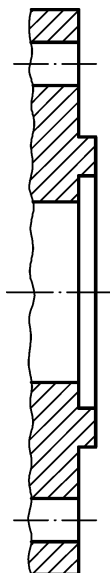

**Type D Groove**

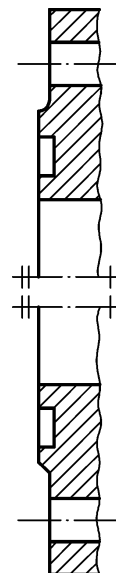

**Type E Spigot**

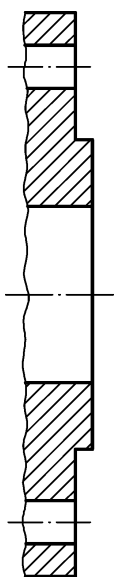

**Type F Recess**

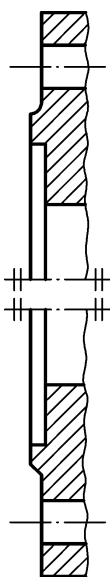

**Type G O-ring Spigot**

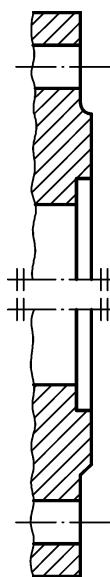

**Type G O-ring Groove**

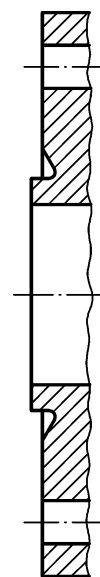

No part of this leaflet may be reproduced in any form or by any means without permission in writing from the publisher.



# Flange Measurement - 1/2

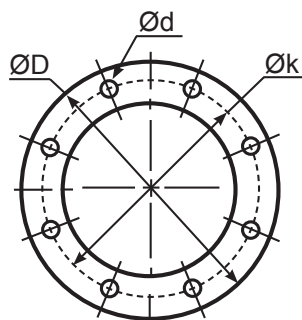

$\varnothing D$  = Diameter  
 $\varnothing k$  = Centre diameter  
 $n$  = Number of holes  
 $\varnothing d$  = Hole diameter

EN 1092-1																	
DN	PN 10				PN 16				PN 25				PN 40				
		$\varnothing D$	$\varnothing k$	n	$\varnothing d$	$\varnothing D$	$\varnothing k$	n	$\varnothing d$	$\varnothing D$	$\varnothing k$	n	$\varnothing d$	$\varnothing D$	$\varnothing k$	n	$\varnothing d$
20	mm	105	75	4	14	105	75	4	14	105	75	4	14	105	75	4	14
	inch	4.13	2.95		0.55	4.13	2.95		0.55	4.13	2.95		0.55	4.13	2.95		0.55
25	mm	115	85	4	14	115	85	4	14	115	85	4	14	115	85	4	14
	inch	4.53	3.35		0.55	4.53	3.35		0.55	4.53	3.35		0.55	4.53	3.35		0.55
32	mm	140	100	4	18	140	100	4	18	140	100	4	18	140	100	4	18
	inch	5.51	3.94		0.71	5.51	3.94		0.71	5.51	3.94		0.71	5.51	3.94		0.71
40	mm	150	110	4	18	150	110	4	18	150	110	4	18	150	110	4	18
	inch	5.91	4.33		0.71	5.91	4.33		0.71	5.91	4.33		0.71	5.91	4.33		0.71
50	mm	165	125	4	18	165	125	4	18	165	125	4	18	165	125	4	18
	inch	6.50	4.92		0.71	6.50	4.92		0.71	6.50	4.92		0.71	6.50	4.92		0.71
65	mm	185	145	4	18	185	145	4	18	185	145	8	18	185	145	8	18
	inch	7.28	5.71		0.71	7.28	5.71		0.71	7.28	5.71		0.71	7.28	5.71		0.71
80	mm	200	160	8	18	200	160	8	18	200	160	8	18	200	160	8	18
	inch	7.87	6.30		0.71	7.87	6.30		0.71	7.87	6.30		0.71	7.87	6.30		0.71
100	mm	220	180	8	18	220	180	8	18	235	190	8	22	235	190	8	22
	inch	8.66	7.09		0.71	8.66	7.09		0.71	9.25	7.48		0.87	9.25	7.48		0.87
125	mm	250	210	8	18	250	210	8	18	270	220	8	26	270	220	8	26
	inch	9.84	8.27		0.71	9.84	8.27		0.71	10.63	8.66		1.02	10.63	8.66		1.02
150	mm	285	240	8	22	285	240	8	22	300	250	8	26	300	250	8	26
	inch	11.22	9.45		0.87	11.22	9.45		0.87	11.81	9.84		1.02	11.81	9.84		1.02
200	mm	340	295	8	22	340	295	12	22	360	310	12	26	375	320	12	30
	inch	13.39	11.61		0.87	13.39	11.61		0.87	14.17	12.20		1.02	14.76	12.60		1.18
250	mm	395	355	12	22	405	355	12	26	425	370	12	30	450	385	12	33
	inch	15.55	13.98		0.87	15.94	13.98		1.02	16.73	14.57		1.18	17.72	15.16		1.30
300	mm	445	400	12	22	460	410	12	26	485	430	16	30	515	450	16	33
	inch	17.52	15.75		0.87	18.11	16.14		1.02	19.09	16.93		1.18	20.28	17.65		1.30

## Flange translation EN 1092 ---- DIN

EN 1092-1	DIN
EN 1092-1 PN 6	DIN 2631
EN 1092-1 PN 10	DIN 2632
EN 1092-1 PN 16	DIN 2633
EN 1092-1 PN 25	DIN 2634
EN 1092-1 PN 40	DIN 2635
EN 1092-1 Type B Raised Face	DIN 2526 Form C
EN 1092-1 Type C Tongue	DIN 2512 Form F
EN 1092-1 Type D Groove	DIN 2512 Form N
EN 1092-1 Type E Spigot	DIN 2513 Form V
EN 1092-1 Type F Recess	DIN 2513 Form R

ООО «ТИ-СИСТЕМС» ИНЖИНИРИНГ И ПОСТАВКА ТЕХНОЛОГИЧЕСКОГО ОБОРУДОВАНИЯ

Интернет: [www.tisys.ru](http://www.tisys.ru) [www.tisys.kz](http://www.tisys.kz) [www.tisys.by](http://www.tisys.by) [www.tesec.ru](http://www.tesec.ru) [www.ти-системс.рф](http://www.ти-системс.рф)

Телефоны: +7 (495) 7774788, 7489626, (925) 5007155, 54, 65

Эл. почта: [info@tisys.ru](mailto:info@tisys.ru) [info@tisys.kz](mailto:info@tisys.kz) [info@tisys.by](mailto:info@tisys.by)

# Flange Measurement - 2/2

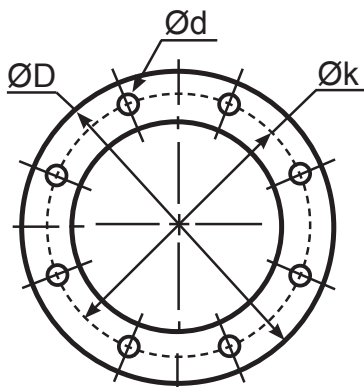

- Ø D = Diameter
- Ø k = Centre diameter
- n = Number of holes
- Ø d = Hole diameter

ANSI (ASA) B 16,5									
INCH		150 psi				300 psi			
		ØD	Øk	n	Ød	ØD	Øk	n	Ød
3/4"	mm	98,4	69,8	4	15,9	117,5	82,5	4	19
	inch	3 7/8	2 3/4		5/8	4 5/8	3 1/4		3/4
1"	mm	107,7	79,4	4	15,9	123,8	88,9	4	19
	inch	4 1/4	3 1/8		5/8	4 7/8	3 1/2		3/4
1 1/4"	mm	117,5	88,9	4	15,9	133,3	98,4	4	19
	inch	4 5/8	3 1/2		5/8	5 1/4	3 7/8		3/4
1 1/2"	mm	127	98,4	4	15,9	155,6	114,3	4	22,2
	inch	5	3 7/8		5/8	6 1/8	4 1/2		7/8
2"	mm	152,4	120,6	4	19	165,1	127	8	19
	inch	6	4 3/4		3/4	6 1/2	5		3/4
2 1/2"	mm	177,8	139,7	4	19	190,5	149,2	8	22,2
	inch	7	5 1/2		3/4	7 1/2	5 7/8		7/8
3"	mm	190,5	152,4	4	19	209,5	168,3	8	22,2
	inch	7 1/2	6		3/4	8 1/4	6 5/8		7/8
4"	mm	228,5	190,5	8	19	254	200	8	22,2
	inch	9	7 1/2		3/4	10	7 7/8		7/8
5"	mm	254	215,9	8	22,2	279,4	234,9	8	22,2
	inch	10	8 1/2		7/8	11	9 1/4		7/8
6"	mm	279,4	241,3	8	22,2	317,5	269,9	12	22,2
	inch	11	9 1/2		7/8	12 1/2	10 5/8		7/8
8"	mm	342,9	298,4	8	22,2	381	330,2	12	25,4
	inch	13 1/2	11 3/4		7/8	15	13		1
10"	mm	406,4	361,9	12	25,4	444,5	387,3	16	28,6
	inch	16	14 1/4		1	17 1/2	15 1/4		1 1/8
12"	mm	482,6	431,8	12	25,4	520,7	450,8	16	31,7
	inch	19	17		1	20 1/2	17 3/4		1 1/4

TW DIN 28459						
	DN	ØD	Øk	n	Ød	
TW1	50	mm	154	130	8	11
		inch	6.06	5.12		0.43
TW1	80	mm	154	130	8	11
		inch	6.06	5.12		0.43
TW3	100	mm	174	150	8	14
		inch	6.85	5.91		0.55
TW5	125	mm	204	176	8	14
		inch	8.03	6.93		0.55
TW7	150	mm	240	210	12	14
		inch	9.45	8.27		0.55

T.T.M.A					
INCH		ØD	Øk	n	Ød
2"	mm	114,3	95,3	6	11,1
	inch	4.50	3.75		0.44
3"	mm	142,9	123,8	8	11,1
	inch	5.63	4.87		0.44
4"	mm	168,3	149,2	8	11,1
	inch	6.63	5.87		0.44
5"	mm	196,9	177,8	12	11,1
	inch	7.75	7.00		0.44
6"	mm	228,6	206,4	12	11,1
	inch	9.00	8.13		0.44
8"	mm	276,2	257,2	16	11,1
	inch	10.87	10.13		0.44

# Flange Connection

## Mounting instruction

When installing Mann Tek equipment to new pipe work, tanks, etc. ensure the system is free from debris that may be transferred through the coupling. Where the hose or loading arm assembly is the primary static dissipation or earth route, the electrical continuity value of the assembly shall be checked to ensure regulatory compliance. Special attention should be paid to the balancing of loading arms. The weight of the coupling plus transfer media should be taken into account at the specification stage. It is usual for loading arm balance settings to account of weight variations due to differences in the full / empty cycle.

The loading arm should be set to balance in the condition present at the time of connection. For example, should the loading arm be empty at the time of connection then it should be balanced in the empty condition.

**The Mann-Tek product can be installed directly in the product line and is ready for use after removing the transport protection. The installation is recommended as follows:**

- Remove the packaging and the flange protection
- Check the coupling for damages before mounting.
- To prevent damages during mounting a suitable wrench should be used for the intended bolts and nuts.
- Ensure that the product line is empty and all valves are close before you connect the coupling into the line.
- Set in all bolts first and tighten them by hand. Then increase the tightening torque in 2 steps up to the recommended value in the following table. Proceed every time according to the sequence shown in g.
- Tightening torque<sup>1)</sup> for bolts:

Metric	
Size	8.8
M8	24 Nm
M10	50 Nm
M12	85 Nm
M16	210 Nm
M20	410 Nm
M22	550 Nm
M24	700 Nm

Inch	
Size	A193 B7
5/16 -18 UNC	16 lbf-ft
3/8 -16 UNC	29 lbf-ft
1/2 -13 UNC	70 lbf-ft
5/8 -11 UNC	139 lbf-ft
3/4 -10 UNC	243 lbf-ft
7/8 -9 UNC	389 lbf-ft
1 -8 UNC	582 lbf-ft

- Bolt tightening sequence.

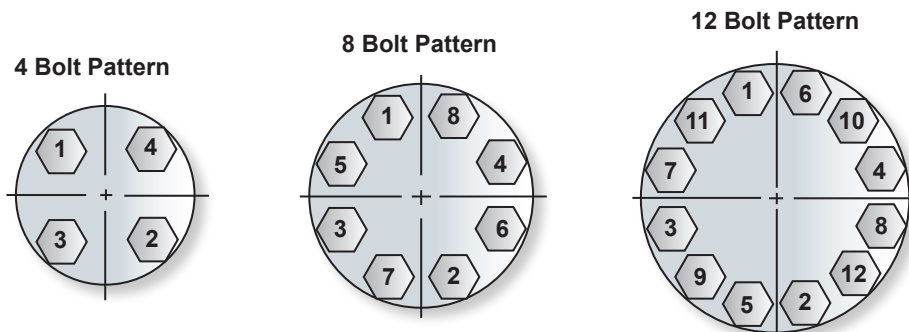

The start-up may take place only when the Mann-Tek product has been mounted as instructed and the necessary function tests and leak tests have been conducted by the approved authorities.

<sup>1)</sup> The torque forces recommended bases on a thread friction coefficient  $\mu=0,14$  and a standard flat seal according to EN 1514-1

# About NPT and BSP threads

## NPT

**Sealing NPT threads can be an exasperating experience if certain techniques are not followed. The following tips will help alleviate many common problems in thread sealing:**

1. Always use some type of sealant (tape or paste) and apply sealant to male thread only. If using a hydraulic sealant, allow sufficient curing time before system is pressurized.

2. When using tape sealant, wrap the threads in a clockwise motion starting at the first thread and, as layers are applied, work towards the imperfect (vanishing) thread. If the system that the connection being made to cannot tolerate foreign matter (i.e. air systems), leave the first thread exposed and apply the tape sealant as outlined above.

3. When using paste sealant, apply to threads with a brush, using the brush to work the sealant into the threads. Apply enough sealant to fill in all the threads all the way around.

4. When connecting one stainless steel part to another stainless steel part that will require future disassembly, use a thread sealant that is designed for stainless steel. This stainless steel thread sealant is also useful when connecting aluminium to aluminium that needs to be disconnected in the future. These two materials gall easily, and if the correct sealant is not used, it can be next to impossible to disassemble.

5. When connecting parts made of dissimilar metals (i.e. steel and aluminium), standard tape or paste sealant performs satisfactory.

6. For sizes 2" and below, tape or paste performs satisfactory. When using thread tape, four wraps (covering all necessary threads) is usually sufficient.

7. For sizes 2½" and above, thread paste is recommended. If thread tape is used, eight wraps (covering all necessary threads) is usually sufficient. Apply more wraps if necessary.

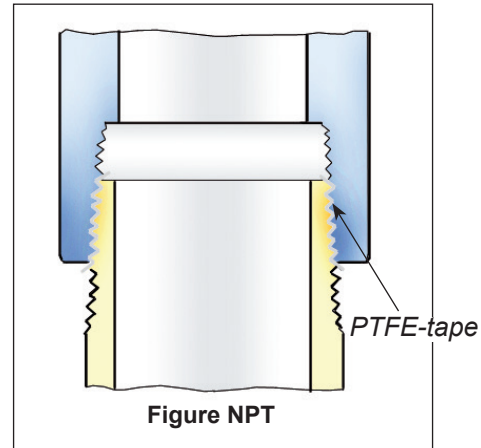

8. For stubborn to seal threads, apply a normal coating of thread paste followed by a normal layer of thread tape.

9. For extremely stubborn to seal threads, apply a normal coating of thread paste followed by a single layer of gauze bandage followed by a normal layer of thread tape.

### Caution!

When this procedure is done, the connection becomes permanent. Extreme measures will be necessary to disconnect these components. All other measures to seal the threads should be explored prior to use of this technique.

10. Over-tightening threads can be just as detrimental as insufficient tightening. For sizes 2" and below, hand tighten the components and, with a wrench, tighten 3 full turns. For sizes 2½" and above, hand tighten the components and, with a wrench, tighten 2 full turns.

## BSP

**The threads are parallel with flat sealing surface.**

This allows to use the full thread length for screwed-on parts. The largest possible transfer of force is guaranteed for short length. The thread seal behind the relief groove of the thread cannot drop out.

Simple screwing down, makes a safe connection. Subsequent tightening during operation is possible at any time. Change of seal and new assembly do not require any expert knowledge.

The European standardisations for hose assemblies require parallel threads with flat seals, because of the advantages.

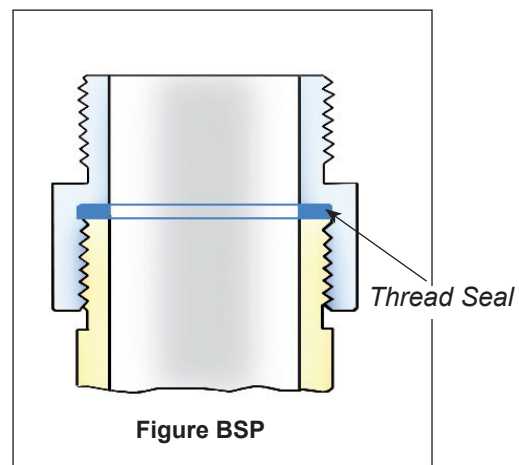

# Flat Seals for thread

weight ≈kg	Thread BSP	Materials Application	Dimensions ≈ mm			Product No
			D	d	s	
0,001	BSP 1/2"	PTFE ( Teflon®) white , massive continuously hard, universally resistant  Teflon® is a registered trademark of DuPont	20	13	2	On request
0,001	BSP 3/4"		26	19	2	1498-06
0,002	BSP 1"		33	24	2	1220-06
0,003	BSP 1 1/4"		42	34	2	1536-06
0,003	BSP 1 1/2"		48	39	2	1196-06
0,004	BSP 2"		60	49	2	1052-06
0,007	BSP 2 1/2"		76	63	2,5	1181-06
0,006	BSP 3"		88	77	3	1110-06
0,009	BSP 4"		114	100	3	1295-06
0,016	BSP 6"		164	150	3	1963-06
0,001	BSP 1/2"	Thermopac asbestos free, light hard. Especially for hot oils and hot bitumen up to 250° C and for hot water and saturated steam up to 25 bar.	20	13	2	On request
0,001	BSP 3/4"		26	19	2	1498-25
0,002	BSP 1"		33	24	2	1220-25
0,002	BSP 1 1/4"		42	34	2	1536-25
0,003	BSP 1 1/2"		48	39	2	1196-25
0,004	BSP 2"		60	49	2	1052-25
0,005	BSP 2 1/2"		76	63	3	1181-25
0,009	BSP 3"		88	77	3	1110-25
0,013	BSP 4"		114	100	3	1295-25
0,016	BSP 6"		164	150	3	1963-25
0,001	BSP 1/2"	FPM/FKM (Viton®) soft for aromatic hydrocarbons and hot oils.  Viton® is a registered trademark of DuPont	20	13	2	On request
0,001	BSP 3/4"		26	19	2	1498-01
0,002	BSP 1"		33	24	2	1220-01
0,002	BSP 1 1/4"		42	34	2	1536-01
0,003	BSP 1 1/2"		48	39	2	1196-01
0,004	BSP 2"		60	49	2	1052-01
0,006	BSP 2 1/2"		76	63	3	1181-01
0,008	BSP 3"		88	77	3	1110-01
0,014	BSP 4"		114	100	3	1295-01
0,016	BSP 6"		164	150	3	1963-01
0,001	BSP 3/4"	PUR (Vulkollan®) Flat seals type of polyurethane, highly resistant to abrasion, non-toxic. Shore hardness=90°. For all petroleum based products and many solvents. Colour:Blue  Vulkollan® is a registe- red trademark of Bayer	26	19	2	1498-09
0,001	BSP 1"		33	24	2	1220-09
0,001	BSP 1 1/4"		42	34	2	1536-09
0,002	BSP 1 1/2"		48	39	2	1196-09
0,003	BSP 1 3/4"		54	44	2,5	On request
0,003	BSP 2"		60	49	2	1052-09
0,005	BSP 2 1/2"		76	63	2,5	1181-09
0,006	BSP 3"		88	77	3	1110-09
0,010	BSP 3 1/2"		100	80	3	On request
0,009	BSP 4"		114	100	3	1295-09
0,012	BSP 5" ( No std)	140	124	3	On request	
0,016	BSP 6"	164	150	3	1963-09	

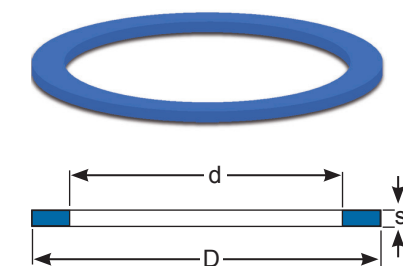
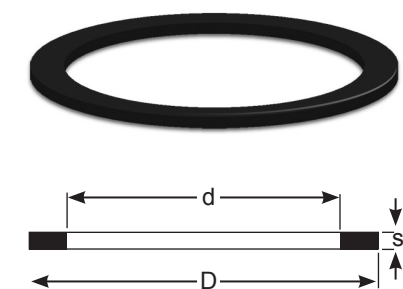
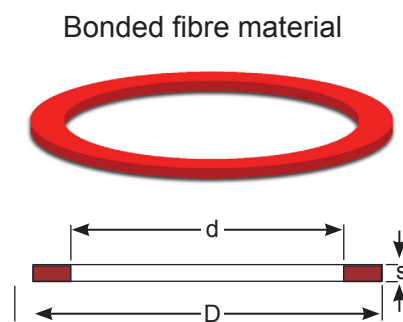
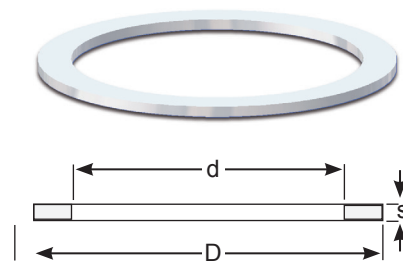

No part of this leaflet may be reproduced in any form or by any means without permission in writing from the publisher.

# Flange Seals

Flange Standard / Suitable for	Dimensions ≈ mm					Product No
	D	d	Øk	Øh	s	
DN 25 PN 10/16	108	78,5	91	4 x 6,5	2	-
DN 32 PN 10/16	140	43	100	4 x 18	2	-
DN 50 PN 6	140	61	110	4 x 15	2	-
DN 50 TW 1	154	50	130	8 x 12	2	-
DN 80 TW 1	154	90	130	8 x 12	2	-
DN 50 PN 10/16	165	61	125	4 x 18	2	-
DN 100 TW3	174	110	150	8 x 14	2	-
DN 65 PN 10/16	185	76	145	4 x 18	2	-
DN 80 PN 10/16	200	90	160	8 x 18	2	-
DN 125 TW5	204	135	176	8 x 14	2	-
DN 100 PN 10/16	220	115	180	8 x 18	2	-
DN 150 TW7	240	160	210	12 x 14	2	-
DN 125 PN 10/16	250	141	210	8 x 18	2	-
DN 150 PN 10/16	280	169	240	8 x 22	2	-
DN 200 PN 10	340	220	295	8 x 22	2	-
DN 200 PN 16	340	220	295	12 x 22	2	-

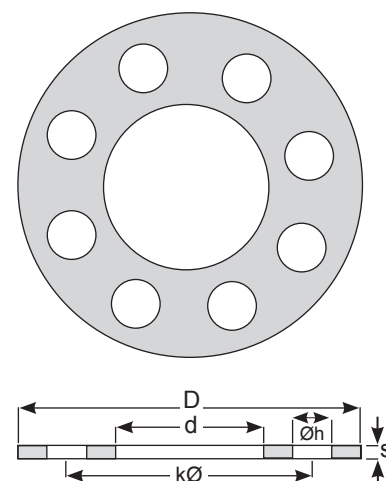

## MATERIAL:

**ELAPAC-FD** is a three component mixture, made of **RUBBER (NBR)** vulcanised, for the adhesion and resistance to kinking.

**CORK** for compressibility and sealing capability. When tightening the flange seal does not move towards the outer or inner edge of the sealing faces. The flange seal does not "settle," and can be re-used in most cases.

**FIBRES** give the material the necessary rigidity and the stability to insert flange seals into narrow gaps from the side. The values for swelling are considerably lower for fibre reinforced mixtures than for plain rubber seals.

**Further advantages:** No leaching out of softening agents. No shrinking or hardening through drying. No influence on or discoloration of media. No hardening at temperature range of -25 o up to +70o Celsius. No sticking on flange. Additional "adhesives" are not necessary. – Therefore good reusability.

## RESISTANCE:

The details refer to fitted flange seals. Only the inner rim of the flange seal is in contact with the medium. In the event of a possible attack this would only result in low penetration and the use is still possible. If the flange seal is completely immersed in the medium during laboratory tests, swelling and loss of stability is of course higher. If the resistance of **ELAPAC** is not sufficient but good compressibility is required, we offer the special design "**TM**" seal which is PTFE encapsulated.

**Application of foodstuffs:** ELAPAC-FD is only suitable with PTFE-cover, otherwise mixture particles can influence the quality of the foodstuffs.

## APPLICATION:

As an elastic flange seal for tank truck and tank plant construction etc., where rough sealing surfaces require

a high adaptability, where flange seals should still have good flexibility to avoid pipe fractures or simple sealing materials because little or no force can be used to tighten the joint. Not suitable for use as thread seal, because the material is too soft and does not have enough lateral strength, this allows the medium to attack the seal material. Also not suitable for applications where the flange seal is only squashed on 2 mm to 3 mm of the total width. Care should be taken not to squash the material to much especially the 2 mm material, if in doubt please use the 3 mm material.

## GAS IMPERMEABILITY :

Due to the fibre content of ELAPAC; gas permeability is to be expected when using seals with narrow width – especially at high vacuum operation.

## APPROVALS:

Approved as flange sealing material for all fuels and lubricants by the German military and the major oil companies for tank trucks, refineries and aircraft refuellers. Approved in 3 mm thickness by the German railway (Mat. No. 150.309). ELAPAC-FD meets the DIN 28 463.

## TECHNICAL DATA:

hardness, Shore	A 86 ± 3
tensile strength	longitudinal 10 N/mm <sup>2</sup> lateral 4,5 N/mm <sup>2</sup>
elongation at break	longitudinal 15 N/mm <sup>2</sup> lateral 70 N/mm <sup>2</sup>
compressibility	75 %
recovery	90 %
compression set 24h, 70° C	40 %
tear resistance	longitudinal 7 N/mm <sup>2</sup> lateral 10 N/mm <sup>2</sup>
working pressure maximal	25 bar
colour	blue
marking	print <b>ELAPAC-FD</b>

# O-ring materials

Designation	Trade name	ISO 1629	ASTM 1418	Temp Range °C		Field of Application
Nitrile Butadiene Rubber	Buna N® Europrene N® Hycar® Nipol N® Perbunan N®	NBR	NBR	-45	110	Standard material for hydraulics and pneumatics. Mineral oil-based hydraulic fluids, animal and vegetable oils and fats. Flame retardant liquids. Aliphatic hydrocarbons (propane, butane, petrol). Silicone oils and greases. Water up to 80°C. Bio oils made from synthetic esters and vegetable oils
Ethylene-Propylene-Diene Rubber	Dutral Keltan® Vistalon® Buna AP®	EPDM	EPDM	-55	120	Hot water, vapour, brake fluids, detergents. Alcohols, ketons, engine coolants, flame retardant phosphate-based liquids, organic and inorganic acids and bases. Not resistant to mineral oils
Fluoroelastomer	Fuorel® Technoflon® Viton®	FPM	FKM	-20	200	Mineral oil and greases. Aliphatic, aromatic and chlorinated hydrocarbons, petrol, 99 octan petrol, diesel fuels, flame retardant phosphatebased liquids. Silicone oils and greases acids, lyes
Fluorosilicone Elastomer	-	MFQ	FVMQ	-60	200	Mineral oils, fuels. lubricant on Di-Ester basis, hot air.
Silicone	Silastic® Silopren®	MVQ	VMQ	-60	200	Mineral oils, fuels. lubricant on Di-Ester basis, hot air.
Hydrogenated Nitrile-Butadiene Rubber	Therban® Tornac® Zetpol®	HNBR**	HNBR**	-35	120	Mineral oil-based hydraulic fluids, animal and vegetable fats, aliphatic hydrocarbons, diesel fuels, ozone, sour gas, dilute acids and bases Mineral oil-based hydraulic fluids, animal and vegetable fats, aliphatic hydrocarbons, diesel fuels, ozone, sour gas, dilute acids and bases
Butyl Rubber	Exxon Butyl® Polysar Butyl®	IIR	IIR	-55	100	Butyl is a copolymer of isobutylene and isoprene. It has largely been replaced by ethylene propylene for O-ring usage. Butyl is resistant to the same fluid types as ethylenepropylene and except for resistance to gas permeation, it is somewhat inferior to ethylene-propylene for O-ring service. Excellent weather resistance, and gas permeation resistance. Poor petroleum oil and fuel resistance.
Perfluorinated Elastomer	CHEMRAZ® Kalrez® PERLAST®	FFPM	FFPM	-40	260	Best chemical resistance of all elastomers, including organic acids, f.i. acetic acid, benzoic acid, formic acid
Chloroprene Rubber	Baypren® Neoprene®	CR	CR	-40	120	Resistant to refrigerants, ammonia, carbon dioxide, freon(R12,R13,R21,R22,R113-R115), silicone oils, water, oxygen(low-pres.), bleaches, caustic soda, alcohols, chlorine, ozone, castor oil and veg. oils. Low resistance to mineral oils!
Polyester / Polyether Urethane Rubber	Adiprene® Urepan® Vulkollan® Desmopan®	AU EU PUR	AU EU	-40	100	Mineral oils and greases, oxygen, ozone. HFA and HFB fluids, air.  Not resistant in esters, aliphatic, aromatic and chlorinated hydrocarbons, concentrated acids and lyes, water above +50°C.
Polytetrafluoroethylene	Teflon®	PTFE	PTFE	-200	260	PTFE is used wherever the chemical and thermal resistance of the normal elastomer is no longer sufficient. These are primarily applications in the chemical industry, foodstuffs industry, pharmaceuticals and medical technology. PTFE are used only as static seals, e.g. on flange connections, on covers, .etc.
Fluorinated Ethylene Propylene	Teflon FEP®	FEP/MVQ	FEP/VMQ	-60	200	FEP is used wherever the chemical and thermal resistance of the normal elastomer is no longer sufficient. These are primarily applications in the chemical industry, foodstuffs industry, pharmaceuticals and medical technology.
		FEP/FPM	FEP/FKM	-20	200	
Perflouralkoxy	Teflon PFA®	PFA/MVQ	PFA/VMQ	-60	250	PFA is used wherever the chemical and thermal resistance of the normal elastomer is no longer sufficient. These are primarily applications in the chemical industry, foodstuffs industry, pharmaceuticals and medical technology.
		PFA/FPM	PFA/FKM	-20	250	
Tetrafluoroethylene-Propylene Copolymer Elastomer	Aflas®	—	TFE / P**	-25	200	Mineral oils and greases, brake fluids, fuels, alcohols, heat transfer media, oils. amines, acids, bases

Viton® (FPM) and Teflon® (FPM/KPM) are registered trademarks of DuPont, DuPont Elastomers. Vulkollan® is registered trademark of Bayer AG

ООО «ТИ-СИСТЕМС» ИНЖИНИРИНГ И ПОСТАВКА ТЕХНОЛОГИЧЕСКОГО ОБОРУДОВАНИЯ

Интернет: [www.tisys.ru](http://www.tisys.ru) [www.tisys.kz](http://www.tisys.kz) [www.tisys.by](http://www.tisys.by) [www.tesec.ru](http://www.tesec.ru) [www.ти-системс.рф](http://www.ти-системс.рф)

Телефоны: +7 (495) 7774788, 7489626, (925) 5007155, 54, 65

Эл. почта: [info@tisys.ru](mailto:info@tisys.ru) [info@tisys.kz](mailto:info@tisys.kz) [info@tisys.by](mailto:info@tisys.by)

## About

Mann Tek is a Swedish manufacturer and supplier of couplings with experience of the industry for more than 20 years. We supply modern, easy to use, safe and timesaving products. A environmentally safe system for both staff and its surroundings, which prevents a variety of hazards.

Our products are the obvious choice in harsh and demanding environments and where there's a need of a safe and spill free handling of fluids, gases and bulk powders. With more than twenty years of knowledge and experience of multiply industries it has accumulated extensive expertise about applications in many types of variations in which our couplings have been, and can be used, with excellent results.



We constantly strive to develop and improve the performance and design of our products, to meet changes, new market demands and standards. Which, today, is what made us market leading.

Our couplings are the obvious choice when certifications and product approvals are required, anywhere in the world.

Mann Tek® is certified to ISO9001:2008 and the products are produced in accordance with several important standards, e.g. the NATO STANAG 3756

## Company Approvals



Mann-Tek is a certified ISO9001-company.